

User Manual

1-phase Hybrid Inverter

SH8.0RS/SH10RS



All Rights Reserved

All Rights Reserved

No part of this document can be reproduced in any form or by any means without the prior written permission of Sungrow Power Supply Co., Ltd (hereinafter "SUNGROW").

Trademarks

SUNGROW and other SUNGROW trademarks used in this manual are owned by SUNGROW.

All other trademarks or registered trademarks mentioned in this manual are owned by their respective owners.

Software Licenses

- It is prohibited to use data contained in firmware or software developed by SUNGROW, in part or in full, for commercial purposes by any means.
- It is prohibited to perform reverse engineering, cracking, or any other operations that compromise the original program design of the software developed by SUNGROW.

About This Manual

The manual mainly contains the product information, as well as guidelines for installation, operation, and maintenance. The manual does not include complete information about the photovoltaic (PV) system. Readers can get additional information at www.sungrowpower.com or on the webpage of the respective component manufacturer.

Validity

This manual is valid for the following model of inverters:

- SH8.0RS
- SH10RS

It will be referred to as "inverter" hereinafter unless otherwise specified.

Target Group

This manual is intended for professional technicians who are responsible for installation, operation, and maintenance of inverters, and users who need to check inverter parameters.

The inverter must only be installed by professional technicians. The professional technician is required to meet the following requirements:

- Know electronic, electrical wiring and mechanical expertise, and be familiar with electrical and mechanical schematics.
- Have received professional training related to the installation and commissioning of electrical equipment.
- Be able to quickly respond to hazards or emergencies that occur during installation and commissioning.
- Be familiar with local standards and relevant safety regulations of electrical systems.
- Read this manual thoroughly and understand the safety instructions related to operations.

How to Use This Manual

Please read this manual carefully before using the product and keep it properly at a place for easy access.

All contents, pictures, marks, and symbols in this manual are owned by SUNGROW. No part of this document may be reprinted by the non-internal staff of SUNGROW without written authorization.

Contents of this manual may be periodically updated or revised, and the actual product purchased shall prevail. Users can obtain the latest manual from support.sungrowpower.com or sales channels.

Security Declaration

For details on the product's network security vulnerability response process and vulnerability disclosure, please visit the following website: <https://en.sungrowpower.com/security-vulnerability-management>.

For more information on network security, please refer to the user manual of the communication module or the Data Logger that comes with the product.

Symbols

This manual contains important safety instructions, which are highlighted with the following symbols, to ensure personal and property safety during usage, or to help optimize the product performance in an efficient way.

Please carefully understand the meaning of these warning symbols to better use the manual.

DANGER

Indicates high-risk potential hazards that, if not avoided, may lead to death or serious injury.

WARNING

Indicates moderate-risk potential hazards that, if not avoided, may lead to death or serious injury.

CAUTION

Indicates low-risk potential hazards that, if not avoided, may lead to minor or moderate injury.

NOTICE

Indicates potential risks that, if not avoided, may lead to device malfunctions or financial losses.

“NOTE” indicates additional information, emphasized contents or tips that may be helpful, e.g., to help you solve problems or save time.

Contents

- All Rights Reserved..... I
- About This Manual..... II
- 1 Safety Instructions..... 1**
 - 1.1 Unpacking and Inspection..... 2
 - 1.2 Installation Safety..... 3
 - 1.3 Electrical Connection Safety..... 3
 - 1.4 Operation Safety..... 5
 - 1.5 Maintenance Safety..... 6
 - 1.6 Disposal Safety..... 7
- 2 Product Description..... 8**
 - 2.1 System Introduction..... 8
 - 2.2 Product Introduction..... 9
 - 2.3 Symbols on the Product..... 10
 - 2.4 LED Panel..... 12
 - 2.5 DC Switch..... 13
 - 2.6 PV Energy Storage System (PV ESS)..... 13
 - 2.6.1 PV Energy Storage System (PV ESS)..... 13
 - 2.6.2 Parallel System..... 15
 - 2.6.3 Declaration For Backup Function..... 18
 - 2.7 Whole Home Backup..... 19
 - 2.8 Retrofitting the Existing PV System..... 20
- 3 Function Description..... 22**
 - 3.1 Safety Function..... 22
 - 3.1.1 Protection..... 22
 - 3.1.2 Earth Fault Alarm..... 22
 - 3.2 Energy Conversion and Management..... 22
 - 3.2.1 Power Derating..... 22
 - 3.2.2 DRM (“AU”/“NZ”)..... 23
 - 3.2.3 Regular Operational Voltage Range..... 23
 - 3.2.4 Regular Operational Frequency Range..... 24
 - 3.2.5 Reactive Power Regulation..... 24
 - 3.2.6 Load Control..... 24
 - 3.3 Battery Management..... 26
 - 3.3.1 Charge Management..... 27

3.3.2 Discharge Management.....	28
3.4 PID Zero.....	29
3.5 Communication and Configuration.....	30
3.6 Import Power Limit Function.....	30
4 Unpacking and Storage.....	31
4.1 Unpacking and Inspection.....	31
4.2 Scope of Delivery.....	32
4.3 Inverter Storage.....	33
5 Mechanical Mounting.....	35
5.1 Safety During Mounting.....	35
5.2 Location Requirements.....	36
5.2.1 Installation Environment Requirements.....	36
5.2.2 Carrier Requirements.....	37
5.2.3 Angle Requirements.....	38
5.2.4 Clearance Requirements.....	38
5.3 Installation Tools.....	39
5.4 Moving the Inverter.....	41
5.5 Installing the Inverter.....	41
6 Electrical Connection.....	44
6.1 Safety Instructions.....	44
6.2 Terminal Description.....	46
6.3 Electrical Connection Overview.....	48
6.4 Backup Wiring Diagram.....	49
6.5 External Protective Grounding Connection.....	54
6.5.1 External Protective Grounding Requirements.....	55
6.5.2 Connection Procedure.....	55
6.6 AC Cable Connection.....	56
6.6.1 AC Side Requirements.....	56
6.6.2 Connecting the AC Cable.....	56
6.7 DC Cable Connection.....	60
6.7.1 PV Input Configuration.....	61
6.7.2 Assembling the PV Connectors.....	62
6.7.3 Installing PV Connector.....	63
6.8 Emergency Load Connection (Backup).....	64
6.9 Battery Connection.....	67
6.9.1 Installing the Battery Connector.....	68
6.10 Communication Connection.....	70
6.10.1 WiNet-S2/EyeM4 Connection.....	70
6.10.1.1 Ethernet Communication.....	72

6.10.1.2 WLAN Communication.....	73
6.10.2 COM2 Terminal Connection.....	74
6.10.2.1 Meter Connection.....	74
6.10.2.2 Battery Communication Connection.....	79
6.10.2.3 DRM Connection.....	80
6.11 DO Connection.....	83
6.12 Protective Cover Installation (Optional).....	84
7 Commissioning.....	87
7.1 Inspection Before Commissioning.....	87
7.2 Powering on the System.....	87
8 iSolarCloud App.....	88
8.1 About iSolarCloud.....	88
8.2 Install iSolarCloud.....	89
8.3 User Roles.....	90
8.4 Device Commissioning.....	90
9 System Decommissioning.....	91
9.1 Decommissioning the Inverter.....	91
9.1.1 Disconnecting the Inverter.....	91
9.1.2 Dismantling the Inverter.....	91
9.1.3 Disposal of Inverter.....	92
9.2 Decommissioning the Battery.....	92
10 Troubleshooting and Maintenance.....	93
10.1 Troubleshooting.....	93
10.2 Maintenance.....	100
10.2.1 Maintenance Notices.....	100
10.2.2 Routine Maintenance.....	102
11 Appendix.....	103
11.1 Technical Data.....	103
11.2 Quality Assurance.....	106
11.3 Contact Information.....	107

1 Safety Instructions

When installing, commissioning, operating, and maintaining the product, strictly observe the labels on the product and the safety requirements in the manual. Incorrect operation or work may cause:

- Injury or death to the operator or a third party.
- Damage to the product and other properties.

WARNING

- **Do not perform any operation on the product (including but not limited to, handling, installing, powering on, or maintaining the product, performing electrical connection, and working at heights) in harsh weather conditions, such as thunder and lightning, rain, snow, and Level 6 or stronger winds. SUNGROW shall not be held liable for any damage to the device due to force majeure, such as earthquakes, floods, volcanic eruptions, mudslides, lightning strikes, fires, wars, armed conflicts, typhoons, hurricanes, tornadoes, and other extreme weathers.**
- **In case of fire, evacuate from the building or product area and call the fire alarm. Re-entry into the burning area is strictly prohibited under any circumstances.**

NOTICE

- **Tighten the screws with the specified torque using tools when fastening the product and terminals. Otherwise, the product may be damaged. And the damage caused is not covered by the warranty.**
- **Learn how to use tools correctly before using them to avoid hurting people or damaging the device.**
- **Maintain the device with sufficient knowledge of this manual and use proper tools.**

- The safety instructions in this manual are only supplements and cannot cover all the precautions that should be followed. Perform operations considering actual onsite conditions.
- SUNGROW shall not be held liable for any damage caused by violation of general safety operation requirements, general safety standards, or any safety instruction in this manual.
- When installing, operating, and maintaining the product, comply with local laws and regulations. The safety precautions in this manual are only supplements to local laws and regulations.
- During the product transport, installation, wiring, maintenance, etc., the materials and tools prepared by users must meet the requirements of applicable local laws and regulations, safety standards, and other specifications. SUNGROW shall not be held liable for any damage to the product caused by the adoption of materials and tools that fail to meet the above-mentioned requirements.
- Operations on the product, including but not limited to, handling, installing, wiring, powering on, maintenance, and use of the product, must not be performed by unqualified personnel. SUNGROW shall not be held liable for any damage to the product resulting from operations done by unqualified personnel.
- Where the transport of the product is arranged by users, SUNGROW shall not be held liable for any damage to the product that is caused by users themselves or the third-party transport service providers designated by the users.
- SUNGROW shall not be held liable for any damage to the product caused by the negligence, intent, fault, improper operation, and other behaviors of users or third-party organizations.
- SUNGROW shall not be held liable for any damage to the product arising from reasons unrelated to SUNGROW.

1.1 Unpacking and Inspection

WARNING

Check all safety signs, warning labels and nameplates on devices. Ensure that the safety signs, warning labels and nameplates must be clearly visible and cannot be removed or covered before the device is decommissioned.

NOTICE

After receiving the product, check whether the appearance and structural parts of the device are damaged, and check whether the packing list is consistent with the actual ordered product. If there are problems with the above inspection items, do not install the device and contact your distributor first. If the problem persists, contact SUNGROW in time.

1.2 Installation Safety

DANGER

- Make sure there is no electrical connection before installation.
- Before drilling, avoid the water and electricity wiring in the wall.

CAUTION

Improper installation may cause personal injury!

- If the product supports hoisting transport and is hoisted by hoisting tools, no one is allowed to stay under the product.
- When moving the product, be aware of the product weight and keep the balance to prevent it from tilting or falling.

NOTICE

Before operating the product, must check and ensure that tools to be used have been maintained regularly.

1.3 Electrical Connection Safety

DANGER

Before electrical connections, please make sure that the inverter is not damaged, otherwise it may cause danger!

Before electrical connections, please make sure that the inverter switch and all switches connected to the inverter are set to "OFF", otherwise electric shock may occur!

DANGER

The PV string will generate lethal high voltage when exposed to sunlight.

- Operators must wear proper personal protective equipment during electrical connections.
- Must ensure that cables are voltage-free with a measuring instrument before touching DC cables.
- Respect all safety instructions listed in relevant documents about PV strings.

⚠ DANGER

Danger to life due to a high voltage inside the inverter!

- **Be sure to use special insulation tools during cable connections.**
- **Note and observe the warning labels on the product, and perform operations strictly following the safety instructions.**
- **Respect all safety instructions listed in this manual and other pertinent documents.**

⚠ DANGER

If the battery is short-circuited, the instantaneous current will be excessively high and a large amount of energy will be released, which may cause fire and personal injury.

Disconnect the battery from all voltage sources prior to performing any work on the battery.

Lethal voltages are present at the battery terminals and cables connecting to the inverter. Severe injuries or death may occur if the cables and terminals in the inverter are touched.

Observe all safety information provided by the battery manufacturer.

⚠ WARNING

Damage to the product caused by incorrect wiring is not covered by the warranty.

- **Electrical connection must be performed by professionals.**
- **Please use measuring devices with an appropriate range. Overvoltage can damage the measuring device and cause personal injury.**
- **All cables used in the PV generation system must be firmly attached, properly insulated, and adequately dimensioned.**
- **Do not damage the ground conductor. Do not operate the product in the absence of a properly installed ground conductor. Otherwise, it may cause personal injury or product damage.**

⚠ WARNING

Check the positive and negative polarity of the PV strings, and connect the PV connectors to corresponding terminals only after ensuring polarity correctness. During the installation and operation of the inverter, please ensure that the positive or negative poles of PV strings do not short-circuit to the ground. Otherwise, an AC or DC short-circuit may occur, resulting in equipment damage. The damage caused by this is not covered by the warranty.

The interfaces of the battery in the system must be compatible with the inverter. The entire battery voltage range must be completely within the permissible range of the inverter, and the battery voltage shall not exceed the maximum permissible DC input voltage of the inverter.

NOTICE

- Comply with the safety instructions related to PV strings and the regulations related to the local grid.
- Install the external protective grounding cable first when performing electrical connection and remove the external protective grounding cable last when removing the inverter.

1.4 Operation Safety

⚠ DANGER

When routing cables, ensure a distance of at least 30 mm between the cables and heat-generating components or areas to protect the insulation layer of cables from aging and damage.

When the product is working:

- Do not touch the product enclosure.
- It is strictly forbidden to plug and unplug any connector on the inverter.
- Do not touch any wiring terminal of the inverter. Otherwise, electric shock may occur.
- Do not disassemble any parts of the inverter. Otherwise, electric shock may occur.
- It is strictly forbidden to touch any hot parts of the inverter (such as the heat sink). Otherwise, it may cause burns.
- Do not connect or remove any battery. Otherwise, electric shock may occur.
- Do not connect or remove any PV string or any PV module in a string. Otherwise, electric shock may occur.
- If the inverter is equipped with a DC switch, do not operate it. Otherwise, it may cause device damage or personal injury.

Do not take other actions, such as setting parameters or cutting off power, during the process of inverter firmware update, to avoid update failure.

1.5 Maintenance Safety

DANGER

Risk of inverter damage or personal injury due to incorrect service!

- Before maintenance, disconnect the AC circuit breaker on the grid side and then the DC switch. If a fault that may cause personal injury or device damage is found before maintenance, disconnect the AC circuit breaker and wait until the night before operating the DC switch. Otherwise, a fire inside the product or an explosion may occur, causing personal injuries.
- After the inverter is powered off, measure the voltage and current with professional instrument. Only when there is no voltage nor current can operators who wear protective equipment operate and maintain the inverter.
- Even if the inverter is shut down, it may still be hot and cause burns. Wear protective gloves before operating the inverter after it cools down.

DANGER

Touching the power grid or the contact points and terminals on the inverter connected to the power grid may lead to electric shock!

- The power grid side may generate voltage. Always use a standard voltmeter to ensure that there is no voltage before touching.

CAUTION

To prevent misuse or accidents caused by unrelated personnel, post prominent warning signs or demarcate safety warning areas around the product.

NOTICE

- If the paint on the inverter enclosure falls or rusts, repair it in time. Otherwise, the inverter performance may be affected.
- Do not use cleaning agents to clean the inverter. Otherwise, the inverter may be damaged, and the loss caused is not covered by the warranty.
- As the inverter contains no parts that can be maintained, never open the enclosure of the inverter or replace any internal components without authorization. Otherwise, the loss caused is not covered by the warranty.
- Do not open the maintenance door in rainy or snowy weather. If it is inevitable, take proper protective measures to avoid the ingress of rainwater and snow into the maintenance compartment; otherwise, the product's operation may be affected.
- Before closing the maintenance door, check whether there is any object left inside the maintenance compartment, such as screws, tools, etc.
- It is recommended for users to use cable sheathing to protect the AC cable. If the cable sheathing is used, make sure it is positioned inside the maintenance compartment.

1.6 Disposal Safety

 WARNING

Please scrap the product in accordance with relevant local regulations and standards to avoid property losses or casualties.

2 Product Description

2.1 System Introduction

The inverter is a transformerless 1-phase hybrid inverter. As an integral component in the power system, the inverter is designed to convert the direct current power generated from the PV modules or batteries into grid-compatible AC current and feeds the AC current to the utility grid.

The 1-phase hybrid inverters are applicable to both on-grid and off-grid PV systems. With the integrated Energy Management System (EMS), they can control and optimize the energy flow so as to increase the self-consumption of the system.

⚠ WARNING

- **The inverter must only be operated with PV strings with class II protection in accordance with IEC 61730, application class A. It is not allowed for the positive pole or the negative pole of the PV strings to be grounded. This can cause the inverter to be destroyed.**
- **Damages to the product due to a faulty or damaged PV installation are not covered by warranty.**
- **Any use other than the one described in this document is not permitted.**
- **During the installation and operation of the inverter, please ensure that the positive or negative polarities of PV strings and those of batteries do not short-circuit to the ground. Otherwise, an AC or DC short-circuit may occur, resulting in equipment damage. The damage caused by this is not covered by the warranty.**
- **Do not short-circuit the Backup port during operation. Otherwise, the inverter or power distribution system will be seriously damaged. The loss is not covered by the SUNGROW warranty.**
- **Do not connect any local load between the inverter and the AC circuit breaker.**

NOTICE

- **For the TT utility grid, the N line voltage to ground must be 30 V or less.**
- **The utility grid must be a TN system for the off-grid application.**
- **The system is not suitable for supplying life-sustaining medical devices. It cannot guarantee backup power in all circumstances.**
- **The inverter applies only to the scenarios described in this manual.**

2.2 Product Introduction

Model Description

The model description is as follows (take SH8.0RS as an example):

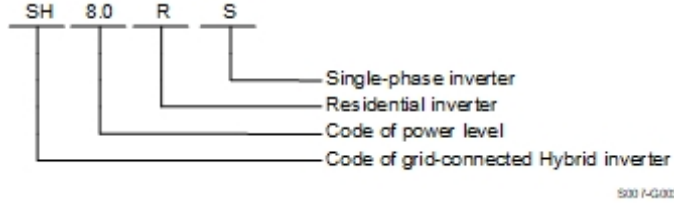

Appearance

The following figure shows the appearance of the inverter. The image shown here is for reference only. The actual product received may differ.

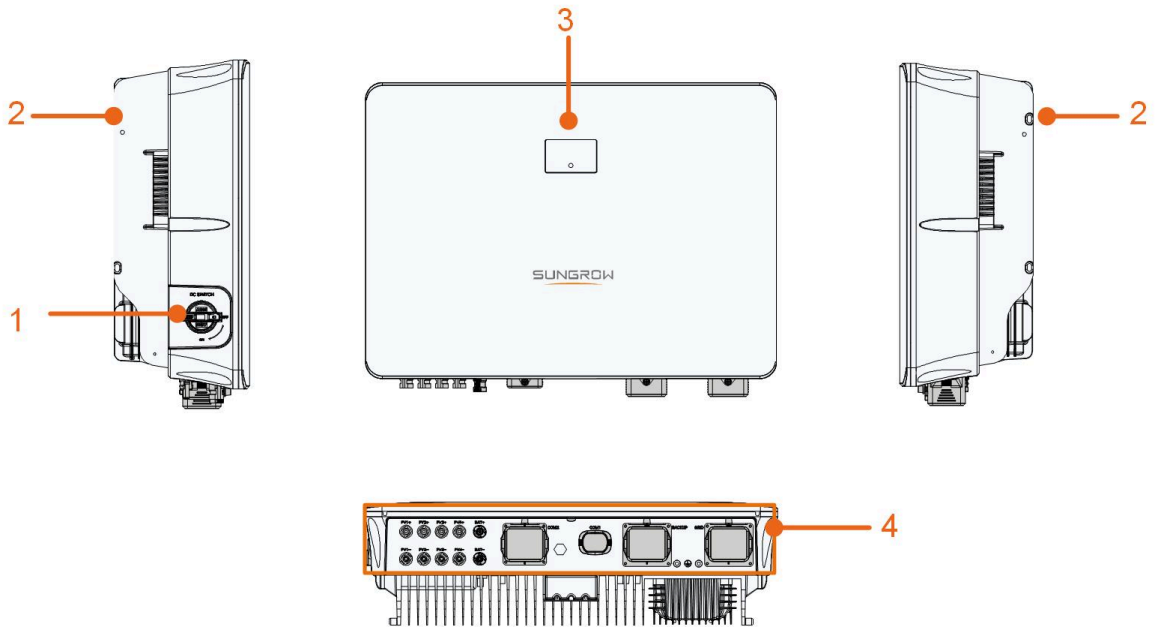

Figure 2-1 Dimensions of the Inverter

No	Name	Description
1	DC switch	To safely disconnect the DC circuit whenever necessary.
2	Hanger	To hang the inverter on the wall-mounting bracket.
3	LED panel	The LED screen indicates the running information and the LED indicator indicates the current working state of the inverter.

No	Name	Description
4	Electrical connection area	PV terminals, battery terminal, AC terminal, additional grounding terminal and communication terminals.

Dimensions

The following figure shows the dimensions of the inverter.

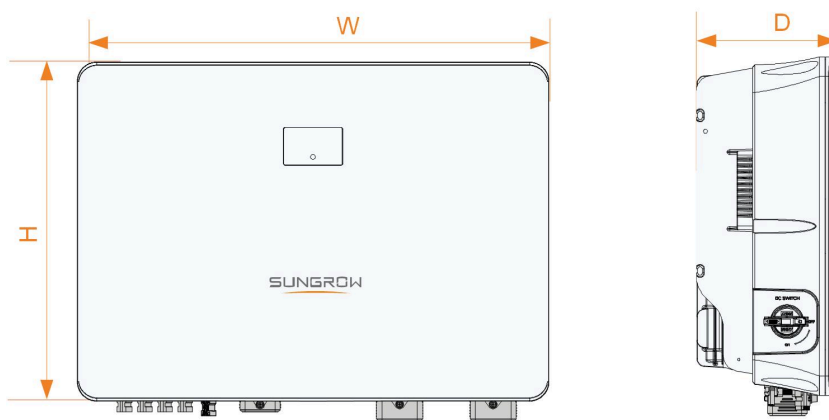

















Figure 2-2 Dimensions of the Inverter

Inverter Model	W (mm)	H (mm)	D (mm)
SH8.0RS / SH10RS	605	435	181

2.3 Symbols on the Product

Symbol	Explanation
	DC parameters on the PV side.
	Parameters on the battery side.
	Parameters on the AC on-grid side.
	Parameters on the AC backup side.
	Regulatory compliance mark.

Symbol	Explanation
	TÜV mark of conformity.
	TÜVRheinland mark of conformity.
	UKCA mark of conformity.
	The inverter does not have a transformer.
	Do not dispose of the inverter together with household waste.
	Disconnect the inverter from all the external power sources before maintenance!
	Danger to life due to high voltages!
	Read the user manual before maintenance!
	Burn danger due to the hot surface that may exceed 60°C.
	Danger to life due to high voltages! Do not touch live parts for 10 minutes after disconnection from the power sources. Only qualified personnel can open and maintain the inverter.
	Additional grounding point.

* The table shown here is for reference only. The actual product received may differ.

Users may also put other warning signs as per the requirements of the local standards or installation specifications.

2.4 LED Panel

The LED panel with a display screen and an indicator is on the front of the inverter.

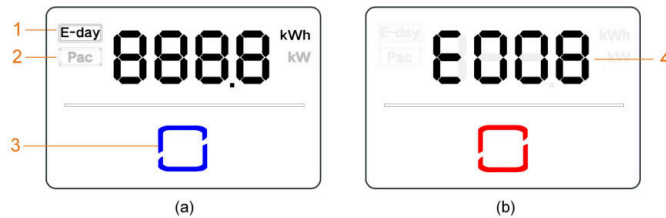

Figure 2-3 LED Panel

(a) Normal state



(b) Error state

No.	Name	Description
1	E-day	Today's energy yield.
2	Pac	Current AC power.
3	LED indicator	To indicate the working state of the inverter. Touch it to switch the information in normal state or view multiple error codes in error state.
4	Error code	The error code in the figure is just an example.

- In normal state, the E-day and Pac information will be displayed alternately. Also you can touch the LED indicator to switch the information.
- In error state, touch the LED indicator to view error codes.
- If there is no operation for 5 minutes, the display screen will be off. Touch the LED indicator to activate it.

Table 2-1 State description of the LED indicator

LED color	State	Definition
 Blue	On	The inverter is operating normally.
	Flashing	The inverter is at standby or startup state (not feeding power into the grid).

LED color	State	Definition
 Red	On	A system fault has occurred.
 Gray	Off	Both the AC and DC sides are powered down.

⚠ WARNING

Voltage may still be present in AC side circuits after the indicator is off. Pay attention to the electricity safety during operating.

2.5 DC Switch

The DC Switch is used to disconnect or connect the PV-DC circuit when AC is turned off or DC current is below 0.5 A.

The inverter operates automatically when input and output requirements are met. Rotate the DC switch to the "OFF" position to stop the inverter when a fault occurs. When you need to stop the inverter normally please first turn off AC and shut down the hybrid via App.

Turn the DC switch to the "ON" position before restarting the inverter.

2.6 PV Energy Storage System (PV ESS)

NOTICE

When designing the system, ensure that the operating ranges of all devices that are connected to the inverter meet the requirements of the inverter.

2.6.1 PV Energy Storage System (PV ESS)

The following figure shows inverter application in a PV energy storage system.

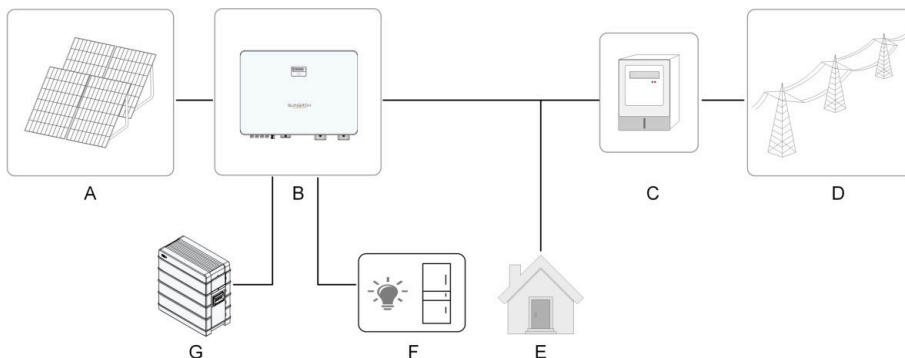
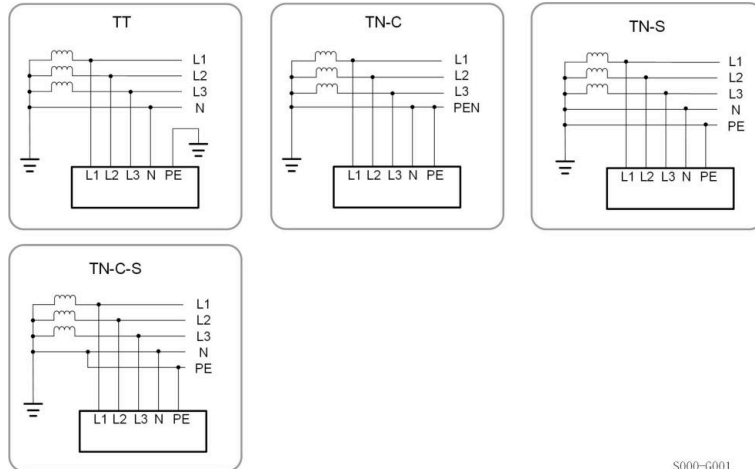

Figure 2-4 PV Energy Storage System

Item	Description	Note
A	PV strings	Compatible with monocrystalline silicon, polycrystalline silicon, and thin-film modules without grounding.
B	Inverter	SH8.0RS, SH10RS
C	Metering device	Meter cupboard with power distribution system.
D	Utility grid	TT,TN-C,TN-S, TN-C-S.
E	Loads	Common loads, which will be lack of power when grid is blackout.
F	Protected house loads	Loads, connected to inverter backup port, which need uninterrupted power supply.
G	Battery (optional)	A Li-ion battery.

The following figure shows the common grid configurations.



S000-G001

2.6.2 Parallel System

Grid-connected Parallel System (Without Backup Load)

At most 3 inverters can be paralleled in this scenario. All the GRID terminals of the hybrid inverters are connected in parallel and no load is connected to the BACK-UP port, as shown in the following figure.

No load is connected to the BACK-UP port in this scenario and the loads are no longer supplied with energy in the event of a grid failure.

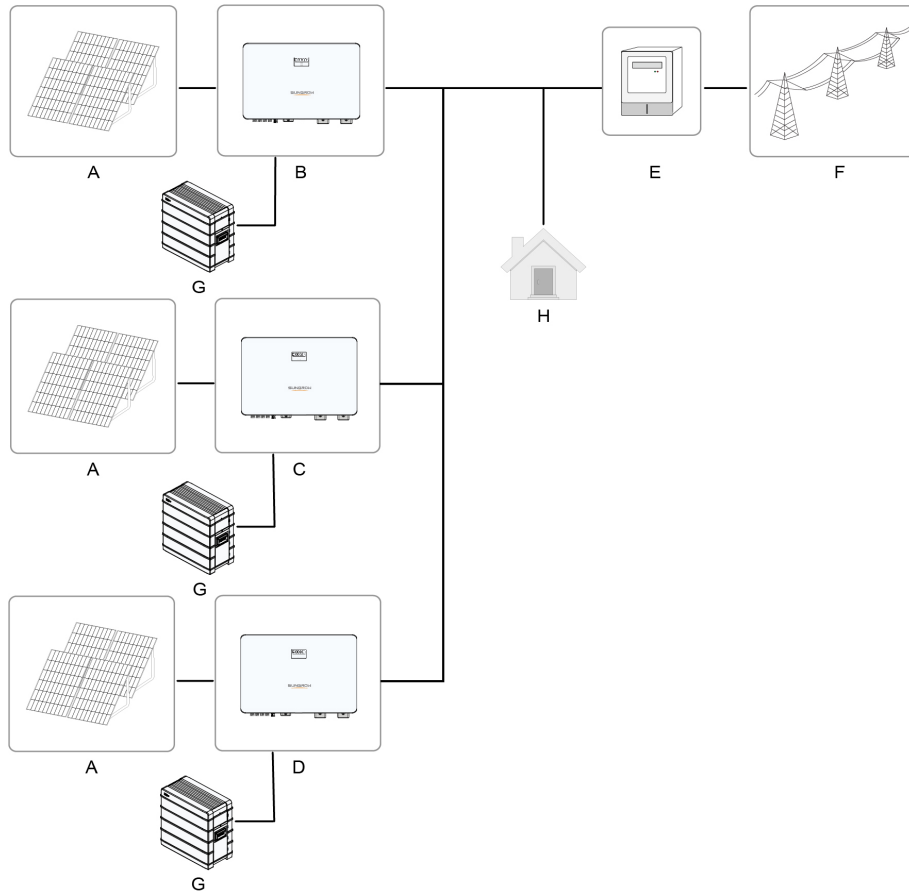

Figure 2-5 Grid-connected Parallel System (Without Backup Load)

Item	Description	Note
A	PV strings	Compatible with monocrystalline silicon, polycrystalline silicon, and thin-film modules without grounding.
B	Master inverter	SH8.0RS, SH10RS
C	Slave inverter 1	SH8.0RS, SH10RS
D	Slave inverter 2	SH8.0RS, SH10RS
E	Metering device	Meter cupboard with power distribution system.
F	Utility grid	TT, TN-C, TN-S, TN-C-S.
G	Battery	A Li-ion battery.

Item	Description	Note
H	Loads	Common loads, which will be lack of power when grid is blackout.

Grid-connected Parallel System (With Backup Load)

At most 3 inverters can be paralleled in this scenario. All the GRID terminals of the hybrid inverters are connected in parallel, but the BACK-UP ports cannot be in parallel. Each BACK-UP port should independently provide power to emergency loads, as shown in the following figure.

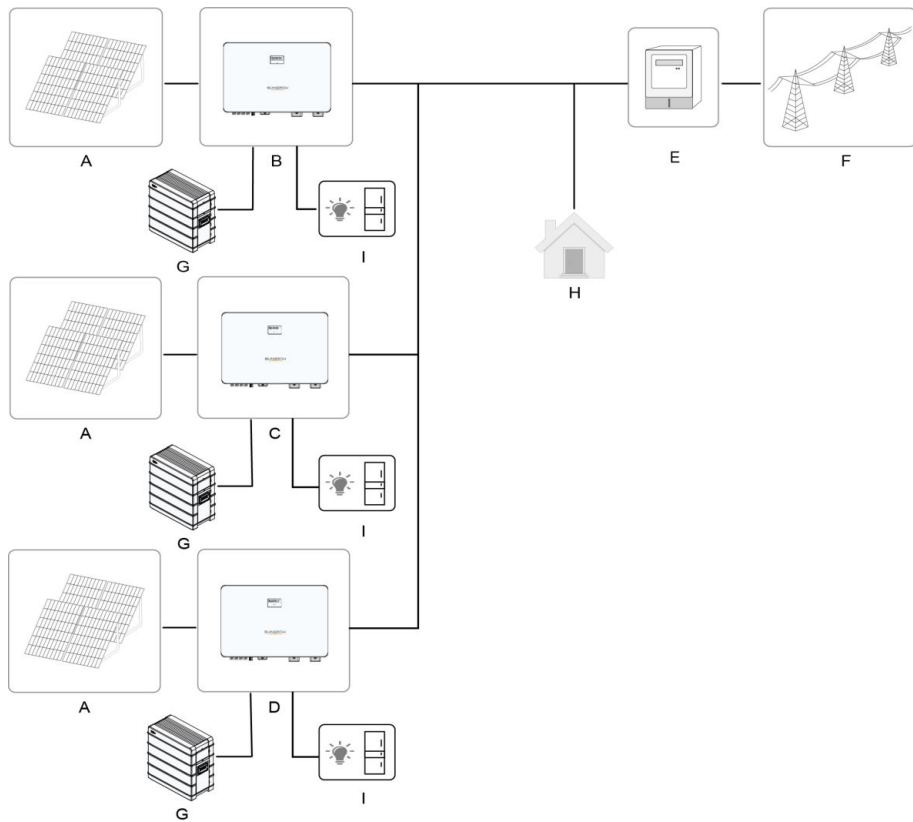

Figure 2-6 Grid-connected Parallel System (With Backup Load)

Item	Description	Note
A	PV strings	Compatible with monocrystalline silicon, polycrystalline silicon, and thin-film modules without grounding.
B	Master inverter	SH8.0RS, SH10RS

Item	Description	Note
C	Slave inverter 1	SH8.0RS, SH10RS
D	Slave inverter 2	SH8.0RS, SH10RS
E	Metering device	Meter cupboard with power distribution system.
F	Utility grid	TT,TN-C,TN-S, TN-C-S.
G	Battery	A Li-ion battery.
H	Loads	Common loads, which will be lack of power when grid is blackout.
I	Protected house loads	Loads, connected to inverter backup port, which need uninterrupted power supply.

The system supports both on-grid and off-grid operation. If the grid fails, the system seamlessly switches to off-grid mode and provides power to the emergency loads connected to each BACK-UP port. When the load power exceeds the PV power, the battery will discharge to provide energy supplement.

2.6.3 Declaration For Backup Function

DANGER

This product is not suitable for supplying power to life-sustaining medical devices since power outages may result in danger to life.

The following statement involves SUNGROW general policies about the hybrid inverters described in this document.

- For hybrid inverters, the electrical installation typically includes connection of the inverter to both PV modules and batteries. If there is no available power from batteries or PV modules in backup mode, the backup power supply will be automatically terminated. SUNGROW shall hold no liability for any consequences arising from failing to observe this instruction.
- Normally, the backup switching time is less than . However, some external factors or local regulations may cause the system to fail on backup mode. Therefore, the users must be aware of conditions and follow the instructions as below:
 - Do not connect loads that are dependent on a stable energy supply for a reliable operation.

- Do not connect the loads whose total capacity is greater than the maximum backup capacity.
- Due to the condition of the battery itself, battery current might be limited by some factors, including but not limited to the temperature and weather.

Declaration For Backup Overload Protection

The inverter will restart in case of Overload Protection. The time required for restarting will increase if Overload Protection repeats. Try to reduce backup load power within maximum limitation or remove the loads which may cause very high start-up current surges.

2.7 Whole Home Backup

In this scenario, in the case of grid outage, energy stored in the PV modules and the battery will be used to supply the loads, so that home appliances can work normally during the outage.

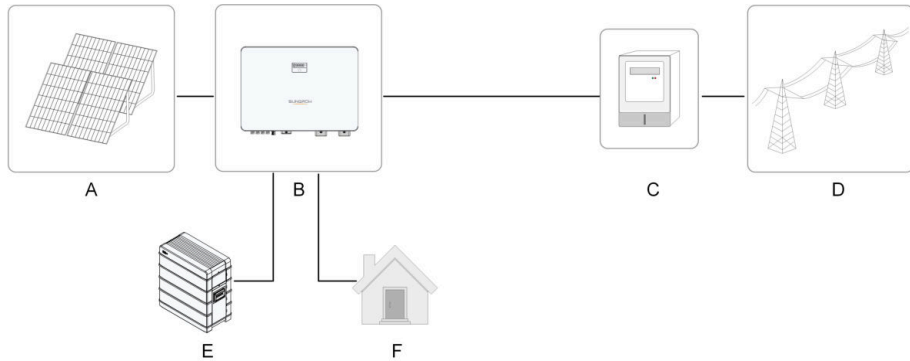

Item	Description	Note
A	PV strings	Compatible with monocrystalline silicon, polycrystalline silicon, and thin-film modules without grounding.
B	Inverter	SH8.0RS, SH10RS
C	Metering device	Meter cupboard with power distribution system.
D	Utility grid	TT, TN-C, TN-S, TN-C-S.
E	Battery (optional)	A Li-ion battery.
F	Loads	House loads, connected to inverter backup port.

Note: 1. In this scenario, the household load should be connected to the backup port.

- The power of household loads connected should not exceed the maximum backup output of the inverter.

2.8 Retrofitting the Existing PV System

The hybrid inverter is compatible with any single-phase PV grid-connected inverters. An existing PV system can be retrofitted to be a PV ESS with the addition of the hybrid inverter.

The power generation from the existing PV inverter will be firstly provided to the loads and then charge the battery. With the energy management function of the hybrid inverter, the self-consumption of the new system will be greatly improved.

This wiring method is not applicable in the European region.

Retrofit the Existing PV Inverter(s) to the Hybrid Inverter On-grid Port

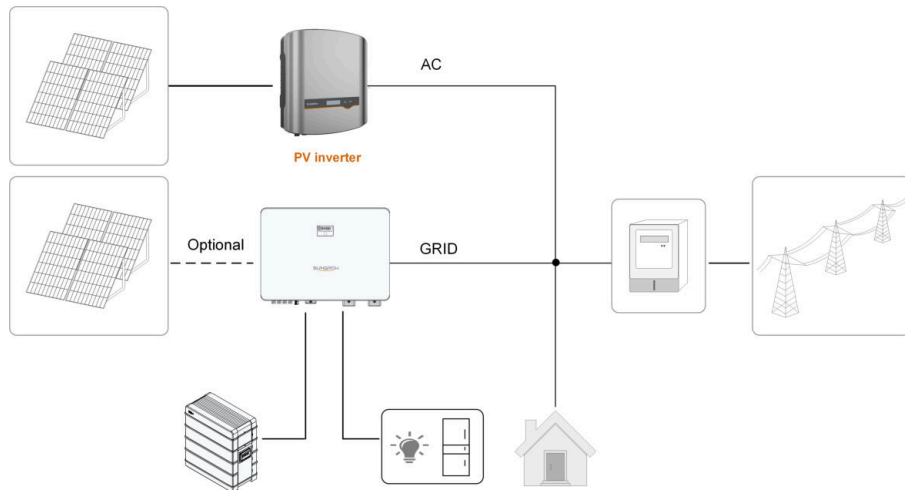

S007-G007

Figure 2-7 Retrofit the Existing PV Inverter(s) to the Hybrid Inverter On-grid Port

The AC terminal of the PV inverter and the GRID terminal of the hybrid inverter are combined to the grid.

Retrofit the Existing PV Inverter(s) to the Hybrid Inverter Off-grid Port

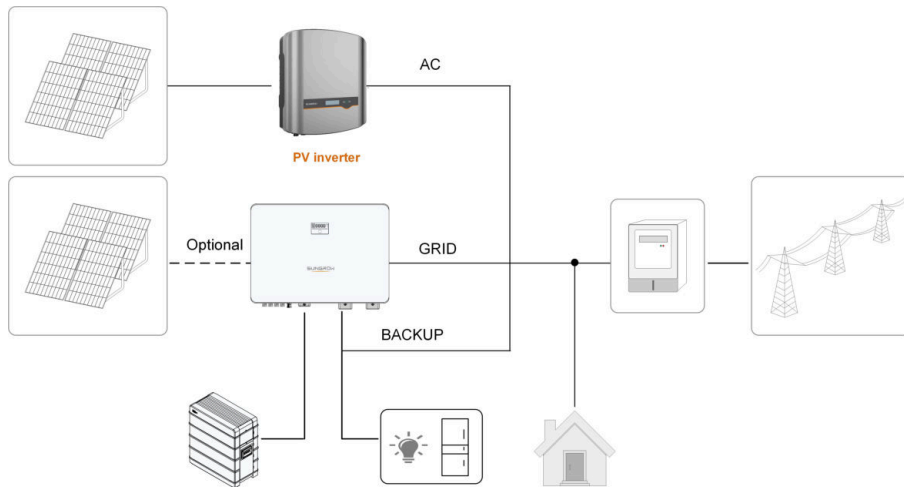

S007-G009

Figure 2-8 Retrofit the Existing PV Inverter(s) to the Hybrid Inverter Off-grid Port

The off-grid port retrofits the existing PV system in order to maximize the use of PV energy by allowing the PV inverter to work even when off-grid.

The AC terminal of the PV inverter and the BACK-UP terminal of the hybrid inverter are combined to the backup loads.

The system can function normally if the rated power of the PV inverter \leq the charge/ discharge capability of the battery that is connected.

- In zero-export scenario, the hybrid inverter can only ensure no power exported to grid itself but does not ensure zero-export for the PV inverter. Please contact the PV inverter manufacturer for its zero-export solution.
- PV modules for hybrid inverter are optional.
- If the system adopts third-party inverters, the electric meter requires 2 CTs for monitoring, with CT1 connected to the grid port and CT2 connected to the AC port of the third-party inverters. If SUNGROW inverters are adopted, only 1 CT is required, and the CT shall be connected to the grid port.

3 Function Description

3.1 Safety Function

3.1.1 Protection

Several protective functions are integrated in the inverter, including short circuit protection, grounding insulation resistance surveillance, residual current protection, anti-islanding protection, DC overvoltage / over-current protection, etc.

3.1.2 Earth Fault Alarm

The device gives an alarm if there is a grounding fault. If the AC side is poorly grounded or not grounded, the buzzer rings, and the LED indicator turns red.

3.2 Energy Conversion and Management

The inverter converts the DC power from the PV array or the battery to the AC power, in conformity with the grid requirements. It also transmits the DC power from the PV panel to the battery.

With the bidirectional converter integrated inside, the inverter can charge or discharge the battery.

Multiple string MPP trackers are used to maximize the power from PV strings with different orientations, tilts, or module structures.

3.2.1 Power Derating

Power derating is a way to protect the inverter from overload or potential faults. In addition, the derating function can also be activated following the requirements of the utility grid.

Situations requiring inverter power derating are:

- over-temperature (including ambient temperature and module temperature)
- high input voltage
- grid under-voltage
- grid over-voltage
- grid over-frequency
- power factor (when values out of the rated values)

3.2.2 DRM (“AU”/“NZ”)

The inverter provides a terminal block for connecting to a demand response enabling device (DRED). The DRED asserts demand response modes (DRMs). The inverter detects and initiates a response to all supported demand response commands within 2s.

The following table lists the DRMs supported by the inverter.

Table 3-1 Demand Response Modes (DRMs)

Mode	Explanation
DRM0	The inverter is in the state of “Turn off”.
DRM1	The import power from the grid is 0.
DRM2	The import power from the grid is no more than 50 % of the rated power.
DRM3	The import power from the grid is no more than 75 % of the rated power.
DRM4	The import power from the grid is 100 % of the rated power, but subject to the constraints from other active DRMs.
DRM5	The feed-in power to the grid is 0.
DRM6	The feed-in power to the grid is no more than 50 % of the rated power.
DRM7	The feed-in power to the grid is no more than 75 % of the rated power.
DRM8	The feed-in power to the grid is 100 % of the rated power, but subject to the constraints from other active DRMs.

The DRED may assert more than one DRM at a time. The following shows the priority order in response to multiple DRMs.

Multiple Modes	Priority Order
DRM1...DRM4	DRM1 > DRM2 > DRM3 > DRM4
DRM5...DRM8	DRM5 > DRM6 > DRM7 > DRM8

Only DRM0 mode has been tested against AS/NZS 4777.2 standard.

3.2.3 Regular Operational Voltage Range

The inverters can operate within the allowable voltage range for at least the specified observation time. The setting of the conditions depends on whether the connection is due to a normal operational start-up or an automatic reconnection after disconnection from grid.

When the voltage level is out of the operational and protection levels, the inverter will disconnect within the specified time from the grid. If a disturbance lasts longer than the required protection time, the inverter can reconnect to the grid once the voltage level goes back to normal levels after the disturbance.

3.2.4 Regular Operational Frequency Range

The inverter can operate within its frequency range for at least the specified observation time. The setting of conditions depends on whether the connection is due to a normal operational start-up or an automatic reconnection after disconnection from grid.

When the frequency level is outside the operational and protection levels, the inverter will disconnect from the grid. If a disturbance lasts longer than the required protection time, the inverter can reconnect to the grid once the frequency level goes back to normal levels after the disturbance.

3.2.5 Reactive Power Regulation

The inverter is capable of operating in reactive power regulation modes for the purpose of providing support to the grid. The reactive power regulation mode can be set via the iSolarCloud App.

3.2.6 Load Control

The inverter has an integrated multiple-function dry-contact (DO relay), which can be used for load control via a contactor.

User may set the control mode according to individual demand.

Tap **More > Settings > Energy Management Parameters > Load Control** to enter the corresponding screen, on which you can set **Load Control Mode**. Load Control Mode includes **Timing Mode**, **Switch Mode**, and **Intelligent Mode**.

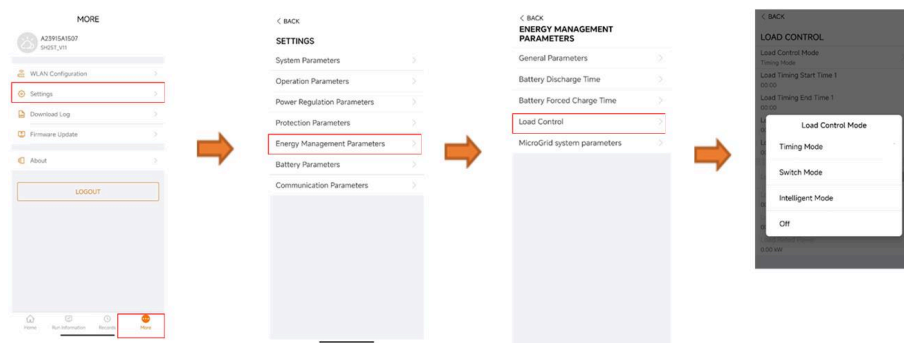

Figure 3-1 Load Control

Timing Mode

In this mode, set the **Load Timing Start Time 1** and **Load Timing End Time 1**, the system will control the load operation during the interval. Take 09:00 am–09:30 am as an example.

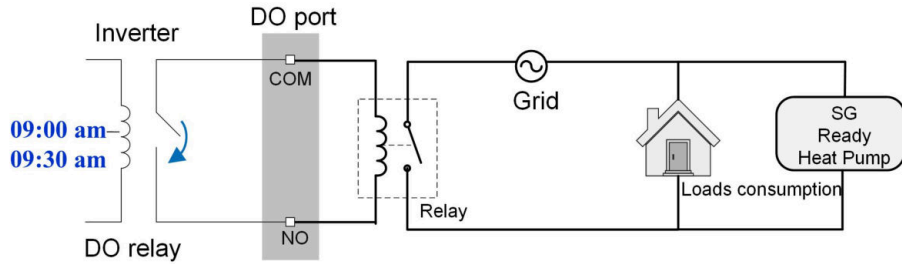

Figure 3-2 DO Operation in Timing Mode Diagram

Switch Mode

In this mode, the system will control the load operation according to the setting. In the following example, the switch is set to OFF.

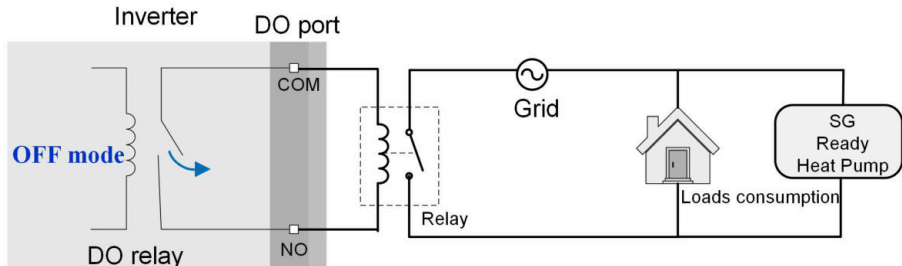

Figure 3-3 DO Operation in Switch Mode Diagram

Intelligent Mode

The system will control the load operation according to the power optimization algorithm of energy management.

During the setting interval, the DO function will be enabled to power on the load if the excess PV energy exceeds the optimized power value.

Notice:

The intelligent mode is disabled in an off-grid system.

- When the inverter is installed to retrofit an existing PV system, the upper limit of optimized power is the sum of the rated power of the hybrid inverter and the rated power of the existing PV inverter.
- Once the intelligent mode is enabled, the DO relay will remain connected for 20 minutes after the DO connection.

Take 09:00 am–09:30 am and the optimized power of 1000 W as an example.

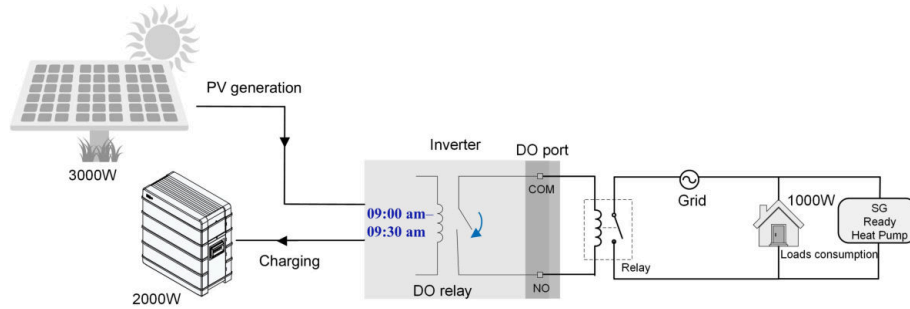

Figure 3-4 DO Operation in Intelligent Mode Diagram

3.3 Battery Management

Li-ion battery from SUNGROW is compatible with the PV ESS, further battery models will be made compatible in the future.

The currently supported battery brands and models are shown in the following table.

Brand	Model	Firmware Version
SUNG	SBR096/128/160/192/224*	≥ SBRBCU-S_22011.01.05
ROW	SBH100/150/200/250/300*	≥ SBHBCU-S_22011.04.02

*SBR224 and SBH300 are supported only in Australia and New Zealand.

The table is continually updated. If the battery model is not in the table, consult SUNGROW if it is supported.

To maximize the battery life, the inverter will perform battery charge, discharge, and battery maintenance based on the battery status communicated by the BMS.

NOTICE

The recommended parameters listed in this section may be updated or revised due to product development. Please refer to the manual supplied by the battery manufacturer for the latest information.

State Definition

In order to avoid overcharging or deep discharging of the battery, three battery statuses according to different voltage ranges has been defined, as shown in the following table.

Table 3-2 Battery Status Definition

Type	Port Voltage / SOC		
	Empty	Normal	Full
SUNGROW (SBR096/128/160 /192/224)	SOC < 5 %	5 %...100 % (by default)	SOC = 100 %
SUNGROW (SBH100/150/200 /250/300)			

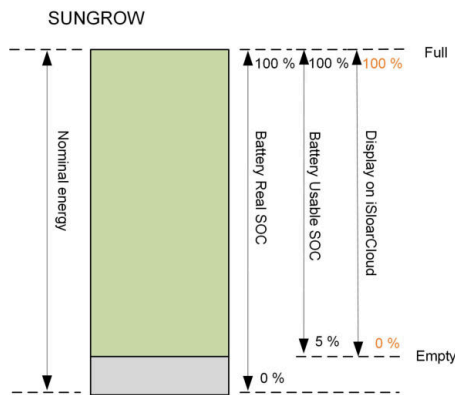

The SOC limits of Li-ion batteries can be modified via the iSolarCloud App by qualified personnel.

NOTICE

If the battery has not been used or fully charged for a long time, it is recommended to fully charge the battery manually every 15 days to ensure battery life and performance.

3.3.1 Charge Management

Backup Charge Management

The emergency charge management function is to protect the battery from the damage caused by long time excessive discharge. The inverter cannot respond to discharge command during emergency charge. The following tables describe the emergency charge conditions for different types of batteries.

Table 3-3 Backup Charge Management for Li-ion Battery

Status	Conditions
Trigger	Either of the following conditions is met: <ul style="list-style-type: none"> • SOC ≤ (Min. SOC) – 3% (valid only when the Min. SOC is ≥ 3 %). • A battery under-voltage warning is triggered.

Status	Conditions
	<ul style="list-style-type: none"> An emergency charge command is reported to the inverter.
Finish	<p>All the following conditions are met:</p> <ul style="list-style-type: none"> SOC \geq (Min. SOC) – 1% (valid only when the Min. SOC is \geq 3 %). The battery under-voltage warning is cleared. The emergency charge command reported to the inverter is cleared.

Table 3-4 Default SOC Conditions for Li-ion Battery Backup Charge

Type	Trigger SOC	Finishing SOC
SUNGROW	SOC \leq 2 %	SOC \geq 4 %

Normal Charge Management

When the battery voltage is within the normal range, the inverter can charge the battery if the PV power is higher than the load power and can ensure that the battery is never over-charged.

The maximum allowable charge current is limited to the smaller value among the following:

- the maximum charge current of the inverter (50A);
- the maximum / recommended charge current from the battery manufacturer.

For this reason, the battery charge power may not reach the nominal power.

- If the PV voltage is higher than the upper limit value of MPP voltage(560 V), the battery cannot charge.
- The hybrid inverter will start to charge the battery when the export power value exceeds a pre-defined threshold value of 70 W.

3.3.2 Discharge Management

Discharge management can effectively protect the battery from deep discharging.

The maximum allowable discharge current is limited to the smaller value among the following:

- the maximum discharge current of the inverter (50A);
- the maximum / recommended discharge current from the battery manufacturer.

For this reason, the battery discharge power may not reach the nominal power.

- If the PV voltage exceeds the upper limit of the MPP voltage (560 V), the battery will not discharge properly. Therefore, it is recommended to maintain the PV voltage below 500 V for optimal performance.
- Temperature derating affects the power drawn from the grid and may trigger derating.
- The battery will not discharge when the load power is below 150W

3.4 PID Zero

The PID Zero function is applicable for both PV and DC-coupled PV plus storage systems. It can suppress PID during the day and intelligently repair PV panels damage caused by PID at night, by relieving or alleviating PV array voltage bias to PV-.

The traditional inverter needs boost circuit to extend the efficient generation time during the day, and break the symmetry of the PV array to the ground voltage, making it closer to the negative electrode. In addition, if the traditional inverter runs at night, the PV array to ground voltage is always limited to the lowest voltage point of the system, which increases the risk of PID.

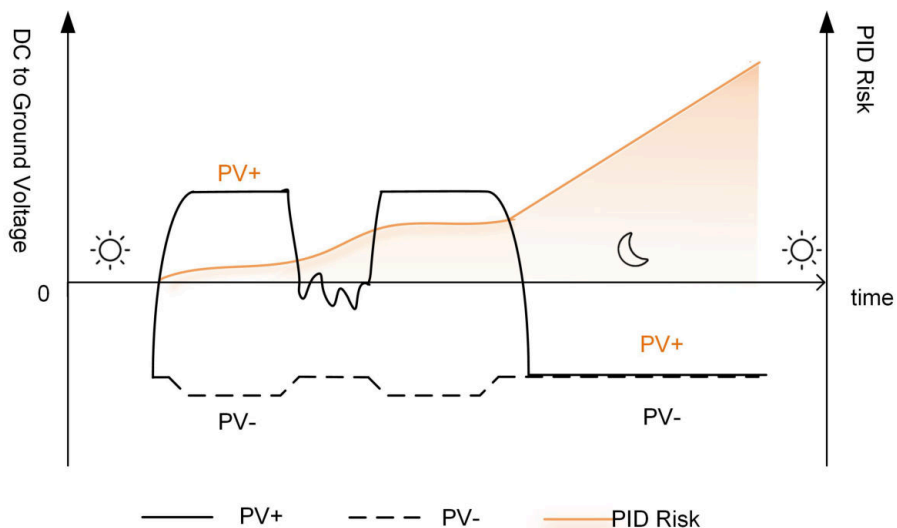

Figure 3-5 PID Risk of Traditional Inverters

The following figure is the PID risk of the inverter equipped with PID Zero, it prevents the PV array voltage from approaching PV-, reduces the risk of PID during daily operation and repairs PV panels caused by PID at night. Details can be found in the *PID Zero White Paper*, which can be obtained on www.sungrowpower.com or from your distributor.

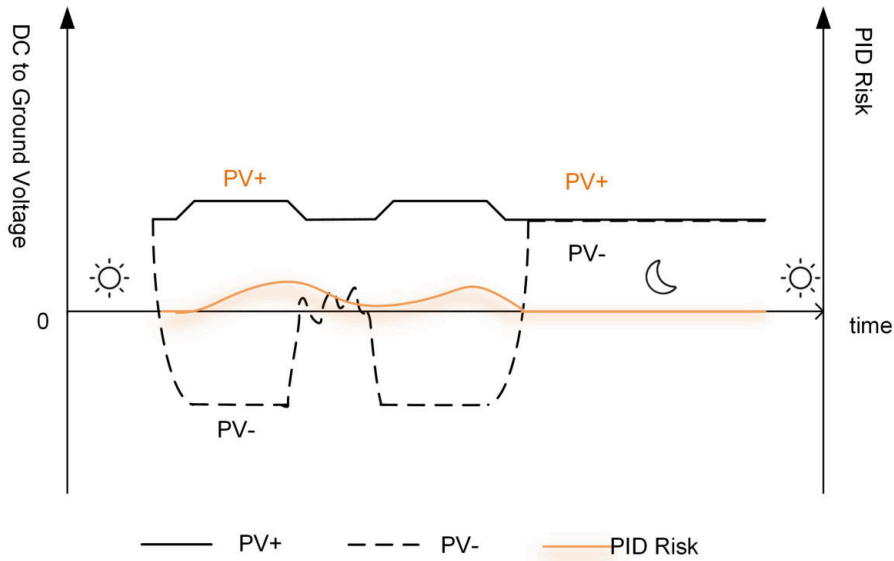

Figure 3-6 PID Risk of Inverters Equipped with PID Zero

⚠ DANGER

Keep the DC switch "ON" in the PID Zero process. During the process, there is voltage hazard between inverter / PV panels live conductors and ground. Do not touch any of them.

3.5 Communication and Configuration

The inverter possesses various ports for device and system monitoring, including RS485, Ethernet, WLAN, and CAN; various parameters can be configured for optimal operation. The inverter information is accessible through the iSolarCloud App.

3.6 Import Power Limit Function

Import power means the total power purchased from grid, which includes power to charge the battery from grid via inverter, power consumed by local loads and loads connected to inverter backup port from grid. Following local regulations, calculate the maximum system tolerable power based on the wire and circuit breaker that required by the selected model, and the value can be set as the **Import Power Limit**. **Import Power Limit** can be set on the iSolarCloud App.

4 Unpacking and Storage

4.1 Unpacking and Inspection

The product is thoroughly tested and strictly inspected before delivery. Nonetheless, damage may still occur during shipping. For this reason, please conduct a thorough inspection after receiving the product.

- Check the packing case for any visible damage.
- Check the scope of delivery for completeness according to the packing list.
- Check the inner contents for damage after unpacking.

Contact SUNGROW or the transport company in case of any damage or incompleteness, and provide photos to facilitate services.

Do not dispose of the original packing case. It is recommended to store the device in the original packing case when the product is decommissioned.

NOTICE

After receiving the product, check whether the appearance and structural parts of the device are damaged, and check whether the packing list is consistent with the actual ordered product. If there are problems with the above inspection items, do not install the device and contact your distributor first. If the problem persists, contact SUNGROW in time.

If any tool is used for unpacking, be careful not to damage the product.

4.2 Scope of Delivery

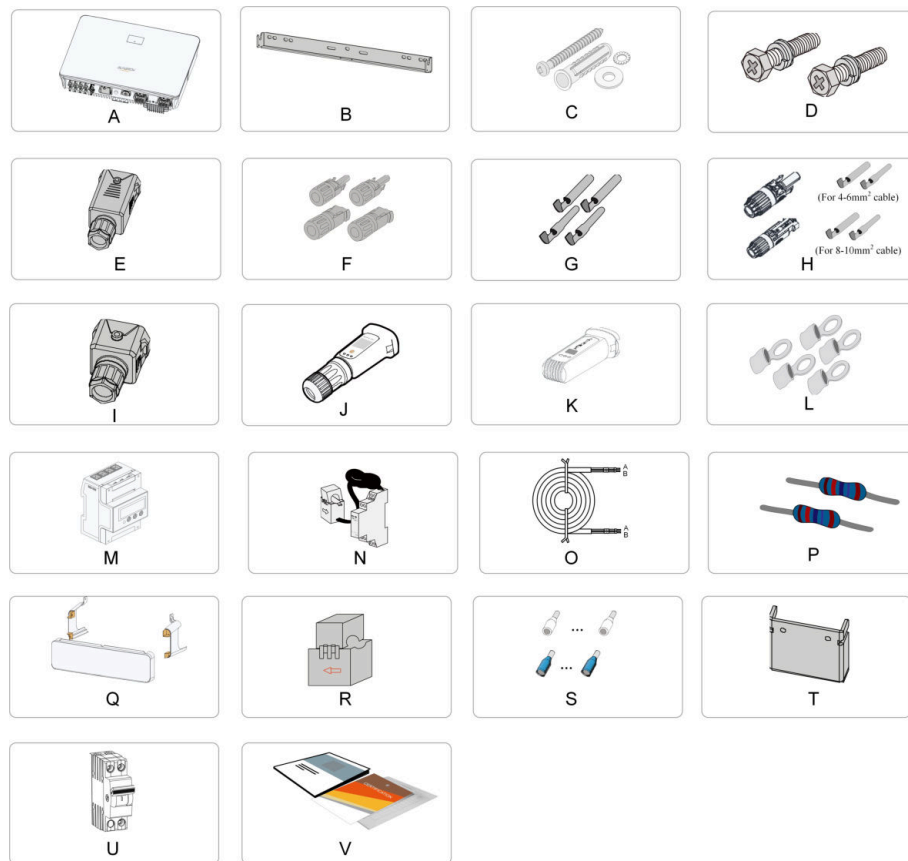

Figure 4-1 Scope of delivery

Item	Name	Quantity
A	Inverter	1
B	Wall-mounting bracket *	1
C	Expansion plug set	3
D	M4×16 screws set	4
E	Backup connector set&Grid connector	2
F	PV connectors	4
G	Crimp contact	4
H	Battery connectors *	1

Item	Name	Quantity
I	COM connector set	1
J	WiNet-S2 module **	1
K	EyeM4 **	1
L	OT terminal *	10
M	Smart Energy Meter**	1
N	Single-phase Meter**	1
O	Meter RS485 cable	1
P	120Ω resistor	2
Q	Protective Cover	1
R	Current Transformer(CT)	2
S	Cord and terminals (for COM2) *	20
T	Bottom Bracket	1
U	Manual changeover switch(63A)	1
V	Documents	1

* The images shown here are for reference. The actual product and quantity are based on delivery.

** Types of equipment to be applied vary in different regions. Please consult local customer service for equipment type selection.

4.3 Inverter Storage

Proper storage is required if the inverter is not installed immediately.

- Store the inverter in the original packing case with the desiccant inside.
- In case of stacking storage, the number of stacking layers should never exceed the limit marked on the outer side of the packing case.
- The packing case should be upright.
- If the inverter needs to be transported again, pack it strictly before loading and transporting it.
- Do not store the inverter in places susceptible to direct sunlight, rain, and strong electric field.
- Do not place the inverter in places with items that may affect or damage the inverter.

- Store the inverter in a clean and dry place to prevent dust and water vapor from eroding.
- Do not store the inverter in places with corrosive substances or susceptible to rodents and insects.
- Carry out periodic inspections. Inspection shall be conducted at least once every six months. If any insect or rodent bites are found, replace the packaging materials in time.
- If the inverter has been stored for one year or longer, or has been mounted but remains non-operational for more than three months, it must be inspected and tested by qualified personnel before being put into operation.

NOTICE

Please store the inverter according to the storage requirements. Product damage caused by failure to meet the storage requirements is not covered by the warranty.

5 Mechanical Mounting

WARNING

Respect all local standards and requirements during mechanical installation.

5.1 Safety During Mounting

DANGER

Make sure there is no electrical connection before installation.
Before drilling, avoid the water and electricity wiring in the wall.

WARNING

For specific requirements for the installation environment, see [5.2.1 Installation Environment Requirements](#). In case the environment where the product is installed does not meet the requirements, SUNGROW shall not be held liable for any property damage arising therefrom.

CAUTION

Improper handling may cause personal injury!

- When moving the product, be aware of its weight and keep the balance to prevent it from tilting or falling.
- Wear proper protective equipment before performing operations on the product.
- The bottom terminals and interfaces of the product cannot directly contact the ground or other supports. The product cannot be directly placed on the ground.

NOTICE

During installation, ensure that no device in the system causes it hard for the DC switch and the AC circuit breaker to act or hinders maintenance personnel from operating.

If drilling is required during installation:

- Wear goggles and protective gloves when drilling holes.
- Make sure to avoid the water and electricity wiring in the wall before drilling.
- Protect the product from shavings and dust.

5.2 Location Requirements

To a large extent, a proper installation location ensures safe operation, service life, and performance of the inverter.

- The inverter should be installed at a height that allows easy viewing of the LED indicator panel, as well as easy electrical connection, operation and maintenance.

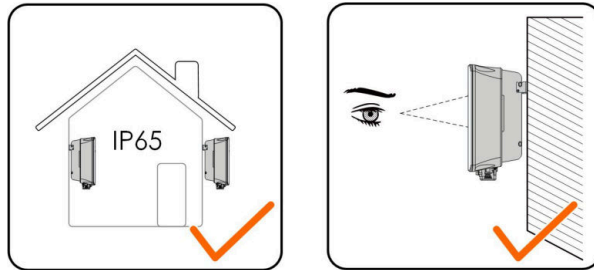

S006-I001

5.2.1 Installation Environment Requirements

- If the inverter is installed in a place with lush vegetation, weed on a regular basis. In addition, the ground beneath the inverter needs to undergo certain treatment, such as laying cement or gravel, etc. (an area of 3 m × 2.5 m is recommended).
- Do not install the inverter in an environment with flammables, explosives, or smoke.
- Do not install the inverter in places prone to water leak, e.g., under the air-conditioner vent, the air vent, or the cable outlet window of the machine room, so as to prevent device damage or short circuit caused by intrusion of water.
- Do not install the inverter in a place with corrosives such as corrosive gas and organic solvent, etc.
- When the inverter is running, its surface may carry high voltages or get very hot. Do not touch it; otherwise, it may lead to burns or electric shocks.
- Do not install the inverter in a place that can be easily reached.
- The installation site must have solid ground, free of rubber-like soils (which cannot be effectively compacted) or weak soils, and should not be prone to subsidence. Also, avoid low-lying areas where water or snow may accumulate. Ensure the site is located above the highest recorded water level in the area.
- Do not install the inverter in a position that could be flooded.
- To prevent vegetation or water on the ground from impacting inverter operation, if the space above meets the designated requirements, elevate the inverter to an appropriate height.
- Install the inverter in a place with shelter, so as to prevent it from getting impacted by direct sunlight and severe weather (e.g., snow, rain, and lightning). The inverter will derate in high temperatures for self-protection. If installed in a place directly exposed to sunlight, as the temperature rises, the inverter may experience power reduction.

- Good heat dissipation is very important to the inverter. Please install the inverter in a ventilated environment.
- Please consult SUNGROW before installing inverters outdoors in areas prone to salt damage, which are mainly coastal areas within 500 meters of the coast. The sedimentation amount of salt spray is correlated to the characteristics of the seawater, sea winds, precipitation, air humidity, topography, and forest coverage in the adjacent sea areas, and there are substantial differences between different coastal areas.
- To ensure device safety and service life, avoid using this product in highly polluted environments containing substances such as sulfur or halogens.
- The inverter is strictly prohibited from being installed in environments with vibration or strong electromagnetic fields (including strong common-mode interference). A strong magnetic field environment refers to one where the magnetic field strength exceeds 30 A/m. The aforementioned environments may cause the product to malfunction.
- In dusty environments such as places full of dust, smoke, or floc, particles may cling to the device's air outlet or heat sink, thus impacting its heat dissipation performance or even getting it damaged. Therefore, do not install the inverter in dusty environments. If the inverter has to be installed in such environments, please clean its fans and heat sink on a regular basis to ensure a good heat dissipation performance.
- The average temperature approximately 1 m around the inverter should be taken as its ambient operating temperature. The temperature and humidity should meet the requirements below:

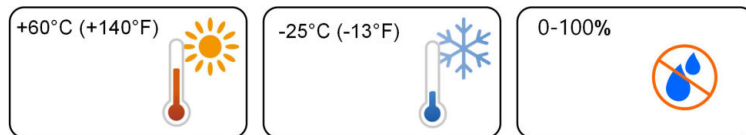

5.2.2 Carrier Requirements

The mounting structure where the inverter is installed must comply with local/national standards and guidelines. Ensure that the installation surface is solid enough to bear four times the weight of the inverter and is suitable for the dimensions of the inverter (e.g. cement walls, plasterboard walls, etc.).

Do not install the inverter on a carrier that may vibrate in resonance, so as to avoid making bigger noise.

Installation on combustible building materials is strictly prohibited. Suitable mounting surfaces include:

Non-combustible wall surfaces: Concrete, fire-resistant gypsum board, brick wall, etc. Non-combustible roof structures: Color-Coated corrugated steel roofing sheets, precast concrete slabs, fiber-reinforced cement boards, etc.



S006-I003

5.2.3 Angle Requirements

Install the inverter vertically. Never install the inverter horizontally, or at forward/backward tilted, side tilted, or upside down.

5.2.4 Clearance Requirements

Reserve enough clearance around the inverter to ensure sufficient space for heat dissipation.

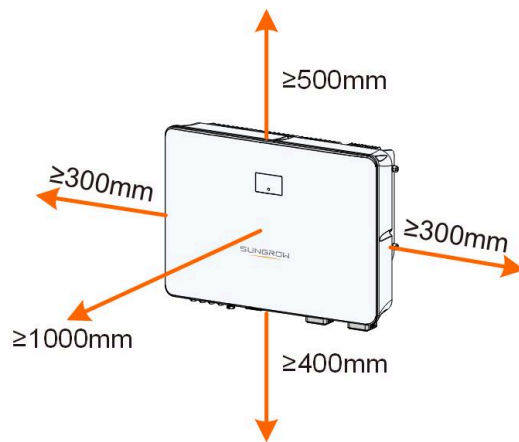

In case of multiple inverters, reserve specific clearance between the inverters.

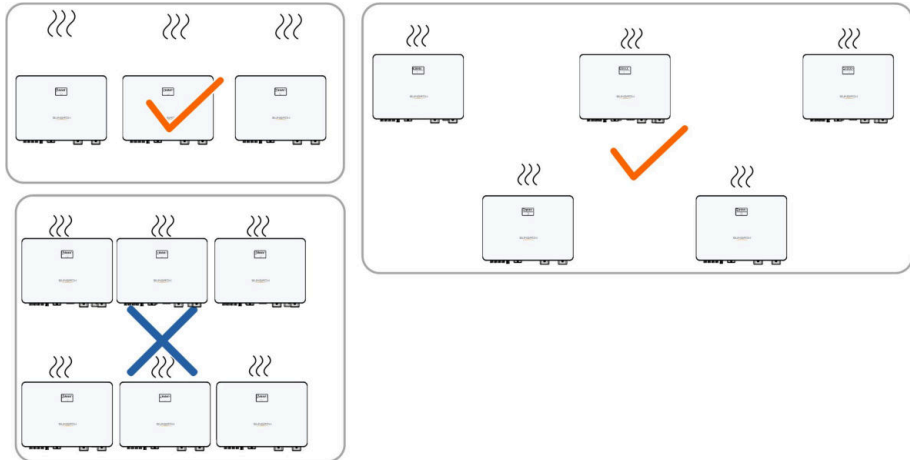









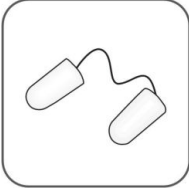
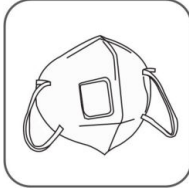

Install the inverter at an appropriate height for ease of viewing the screen and LED indicator and operating switch(es).

5.3 Installation Tools

Installation tools include but are not limited to the following recommended ones. If necessary, use other auxiliary tools on site.

Table 5-1 Tool specification

			
Goggles	Earplugs	Dust mask	Protective gloves
			
Insulated shoes	Utility knife	Marker	Wrist strap
			

Wire cutter



Wire stripper



Hydraulic plier

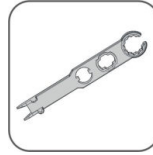

RJ45 crimping tool



MC4 terminal crimping tool (4 mm²–6 mm²)



Rubber mallet

Battery terminal crimping tool (4 mm²–6 mm², 10mm²)

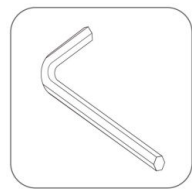

Allen wrench (H4)

MC4 wrench

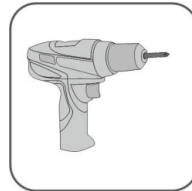

Electric screwdriver (M4, M5, M6)

Tube terminal crimping tool (0.5 mm²–1.0 mm²)



Hammer drill (φ10)



Phillips screwdriver (M4)



Vacuum cleaner

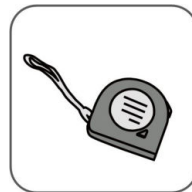

Measuring tape

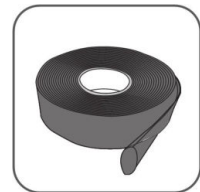

Heat shrink tubing



Heat gun



Wrench (33 mm, 35 mm)

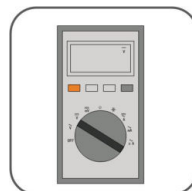

Multimeter (≥ 600 Vdc)

5.4 Moving the Inverter

Before installation, remove the inverter from the packing case and move it to the installation site. Follow the instructions below as you move the inverter:

- Always be aware of the weight of the inverter.
- Lift the inverter using the handles positioned on both sides of the inverter.
- Move the inverter by one or two people or by using a proper transport tool.
- Do not release the equipment unless it has been firmly secured.

⚠ CAUTION

Improper handling may cause personal injury!

- **Arrange an appropriate number of personnel to carry the inverter according to its weight, and installation personnel should wear protective equipment such as anti-impact shoes and gloves.**
- **Attention must be paid to the center of gravity of the inverter to avoid tilting during handling.**
- **Placing the inverter directly on a hard ground may cause damage to its metal enclosure. Protective materials such as sponge pad or foam cushion should be placed underneath the inverter.**
- **Move the inverter by holding the handles on it. Do not move the inverter by holding the terminals.**

5.5 Installing the Inverter

Inverter is installed on the wall by means of wall-mounting bracket and the expansion plug sets.

The expansion plug set shown below is recommended for the installation.

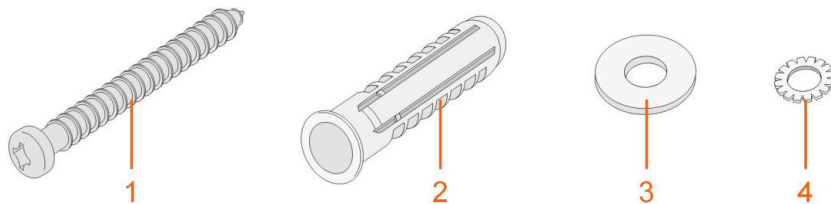

(1) Self-tapping
screw M6

(2) Expansion
tube

(3) Fender washer

(4) Spring washer

Step 1 Place the wall-mounting bracket to a proper position on the wall. Mark the positions and drill the holes.

NOTICE

**Observe the level on the bracket and adjust until the bubble is in the middle position.
The depth of the holes should be about 70 mm.**

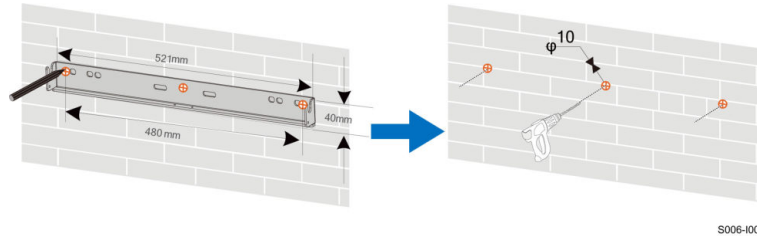

* The image shown here is for reference only. The actual product received may differ.

Step 2 Place the expansion tubes into the holes. Then secure the wall-mounting bracket to the wall firmly with the expansion bolt sets.

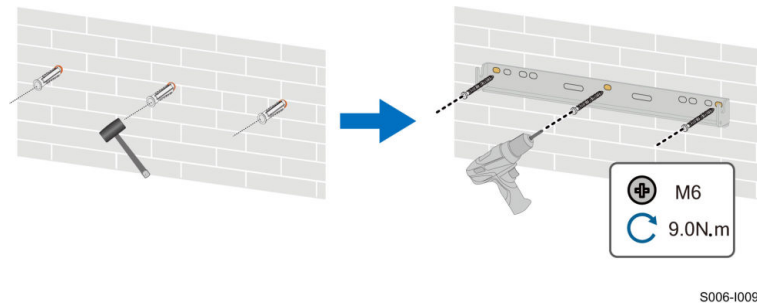

Step 3 Install the bottom bracket to avoid the inverter tilting forward.

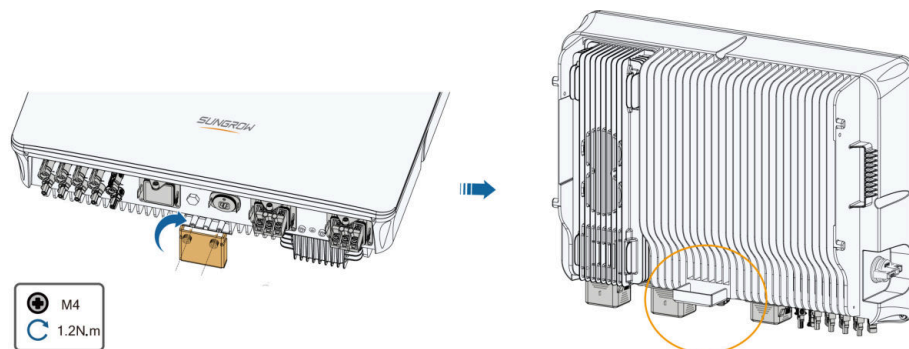

Step 4 Lift the inverter and slide it down along the wall-mounting bracket to make sure they match perfectly. Use one screw set to lock either left or right sides.

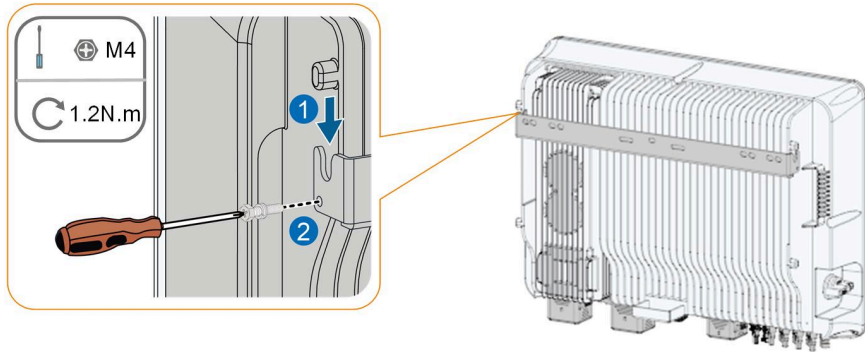

--End

6 Electrical Connection

6.1 Safety Instructions

DANGER

The PV string will generate lethal high voltage when exposed to sunlight.

- Operators must wear proper personal protective equipment during electrical connections.
- Must ensure that cables are voltage-free with a measuring instrument before touching DC cables.
- Respect all safety instructions listed in relevant documents about PV strings.

DANGER

- Before electrical connections, please make sure that the inverter switch and all switches connected to the inverter are set to "OFF", otherwise electric shock may occur!
- Ensure that the inverter is undamaged and all cables are voltage free before performing electrical work.
- Do not close the AC circuit breaker until the electrical connection is completed.

WARNING

Do not damage the ground conductor. Do not operate the product in the absence of a properly installed ground conductor. Otherwise, it may cause personal injury or product damage.

Please use measuring devices with an appropriate range. Overvoltage can damage the measuring device and cause personal injury.

Damage to the product caused by incorrect wiring is not covered by the warranty.

- Electrical connection must be performed by professionals.
- Operators must wear proper personal protective equipment during electrical connections.
- All cables used in the PV generation system must be firmly attached, properly insulated, and adequately dimensioned. Cables used shall comply with the requirements of local laws and regulations.
- The factors that affect cable selection include rated current, cable type, routing mode, ambient temperature, and maximum expected line loss.

NOTICE

All electrical connections must comply with local and national/regional electrical standards.

- Cables used by the user shall comply with the requirements of local laws and regulations.
- Only with the permission of the national/regional grid department, the inverter can be connected to the grid.

NOTICE

- Install the external protective grounding cable first when performing electrical connection and remove the external protective grounding cable last when removing the inverter.
- Keep the AC output cable and the DC input cable close to each other during electrical connection.
- Comply with the safety instructions related to PV strings and the regulations related to the utility grid.

NOTICE

- After being crimped, the OT terminal must wrap the wires completely, and the wires must contact the OT terminal closely.
- When using a heat gun, protect the device from being scorched.
- Keep the PV+ cable and PV- cable close to each other when connecting DC input cables.
- Before connecting a power cable (such as the AC cable, the DC cable, etc.), confirm that the label and identifier on the power cable are correct.
- When laying out communication cables, separate them from power cables and keep them away from strong interference sources to prevent communication interruption.
- All vacant terminals must be covered with waterproof covers to prevent affecting the protection performance.
- Ensure that AC output cables are firmly connected. Failing to do so may cause inverter malfunction or damage to its AC connectors.
- When the wiring is completed, seal the gap at the cable inlet and outlet holes with fireproof/waterproof materials such as fireproof mud to prevent foreign matter or moisture from entering and affecting the long-term normal operation of the inverter.

The cable colors in figures in this manual are for reference only. Please select cables according to local cable standards.

6.2 Terminal Description

All electrical terminals are located at the bottom of the inverter.

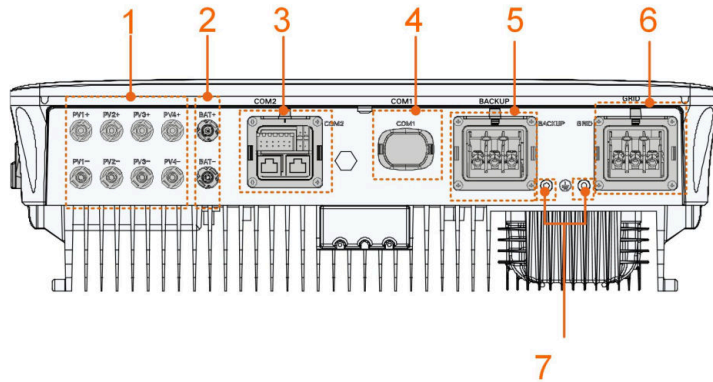

S007-E001

Figure 6-1 Terminals

* The image shown here is for reference only. The actual product received may differ.

Table 6-1 Terminal Description

N o.	Name	Description	Decisive Voltage Classification
1	PV1+, PV1-, PV2+, PV2-, PV3+, PV3-, PV4+, PV4-	MC4 terminals for PV input. The terminal number depends on inveter model.	DVC-C
2	BAT+, BAT-	Connectors for the battery power cables	DVC-C
3	COM2	Communication connection for RSD, BMS, RS485, DRM/DI, DO and smart energy meter.	DVC-A
4	COM1	Communication accessory port to be connected to WiNet-S2/EyeM4 communication module.	DVC-A
5	BACKUP	AC terminal for Backup loads	DVC-C
6	GRID	AC terminal to connect to the grid.	DVC-C
7		Additional grounding terminal.	Not applicable

The pin definition of COM2 terminal is shown in the following label.

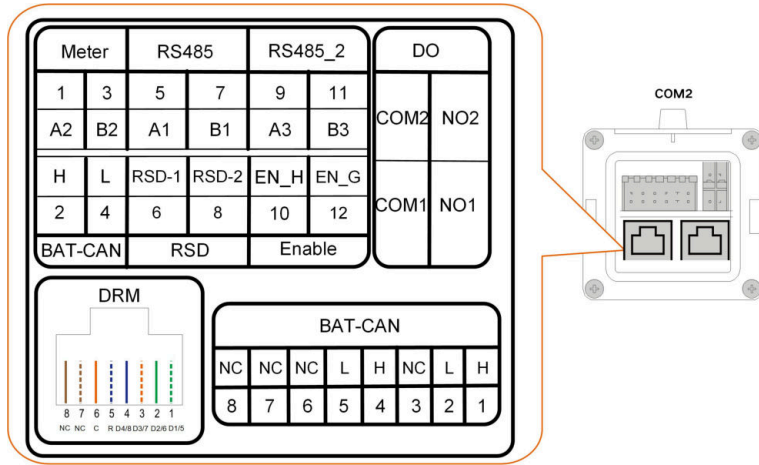

Figure 6-2 Label of COM2 Terminal

Table 6-2 Label Description of COM2 Terminal

Label	Description	
Meter	A2, B2	For Smart Energy Meter
BAT-CAN	H, L	For Li-ion battery communication via CAN protocol.
RS485	A1, B1	For inverter daisy chain (Reserved) For Li-ion battery communication via RS485 protocol.
RSD	RSD-1, RSD-2	Reserved (Detail availability contact SUNGROW)
RS485_2	A3, B3	For EV Charger communication via RS485 protocol.
Enable	EN_H, EN_G	Enable the battery with a voltage of 12V.
DO	COM1, COM2, NO1, NO2	Reserved (Detail availability contact SUNGROW)
DRM	D1/5, D2/6, D3/7, D4/8, R, C	For external Demand Response Enabling Device ("AU"/"NZ") For Ripple Control Receiver

No.	Cable	Type	Cable Diameter	Cross-section
		with 600 V and 16 A standard		
3	Communication cable	Shielded twisted pair	4.8 – 6 mm	0.5 – 1.0 mm ² (20 - 17 AWG)
		CAT 5E outdoor shielded network cable*	4.8 – 6 mm	0.08 – 0.2 mm ² (28 - 24AWG)
4	Backup cable AC cable	Outdoor 3-core copper wire cable	21 – 25.8 mm	14 – 16 mm ² (6 - 5AWG)
5	Additional Grounding cable	Outdoor single-core copper wire cable	The same as that of the PE wire in the AC cable	

If local standard have other requirements for cables, set the cable specification according to the local standard.

*To meet shielding and anti-interference requirements:

- Shielded Ethernet cables are mandatory. It is recommended to use CAT 5E or CAT 6 shielded cables.
- Use Ethernet cables with magnet cores at both ends, and in some cases, add magnet cores in the middle.

6.4 Backup Wiring Diagram

For AU/NZ/SA

For Australia, New Zealand and South Africa, the neutral cable of GRID side and BACK-UP side must be connected together. Otherwise BACK-UP function will not work.

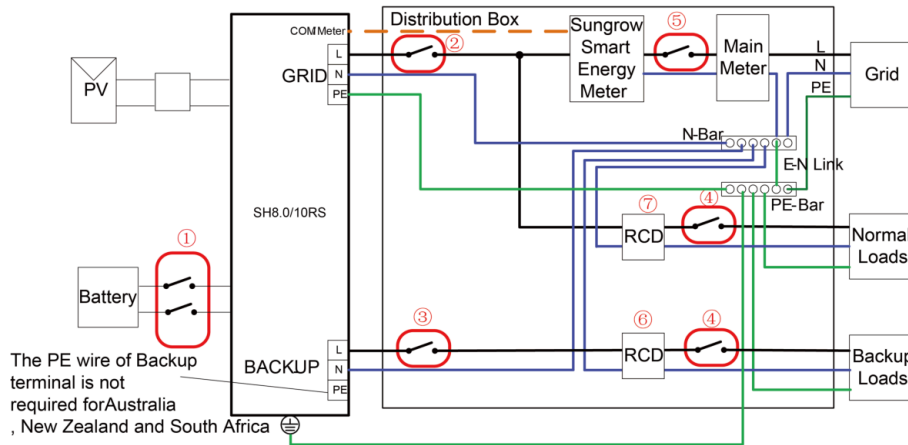

This wiring diagram is for reference only. Please confirm the actual wiring requirements for different regions with SUNGROW.

NO.	SH8.0/10RS
①	63A/600V DC breaker *
②	≤63A/230V/400V TypeC AC breaker
③	63A/230V/400V TypeC AC breaker
④	Depends on loads
⑤	Depends on household loads and inverter capacity
⑥⑦	30mA RCD (Comply with local regulation)

Note 1: * If the battery is integrated with a readily accessible internal DC breaker, no additional DC breaker is required.

Note 2: The recommended values in the table are for reference only. The actual values must comply with local standard and actual conditions.

Note 3: The rated current of breaker ② is suggested to lower than that of breaker ⑤.

Note 4: If the rated current of on-site power cables are lower than those recommended above, the breakers specification should be considered to match the power cables in first priority.

Note 5: The AC port takes power from the grid and is set according to the grid circuit breaker.

For other countries

For other countries, the following diagram is an example for grid systems without special requirement on wiring connection.

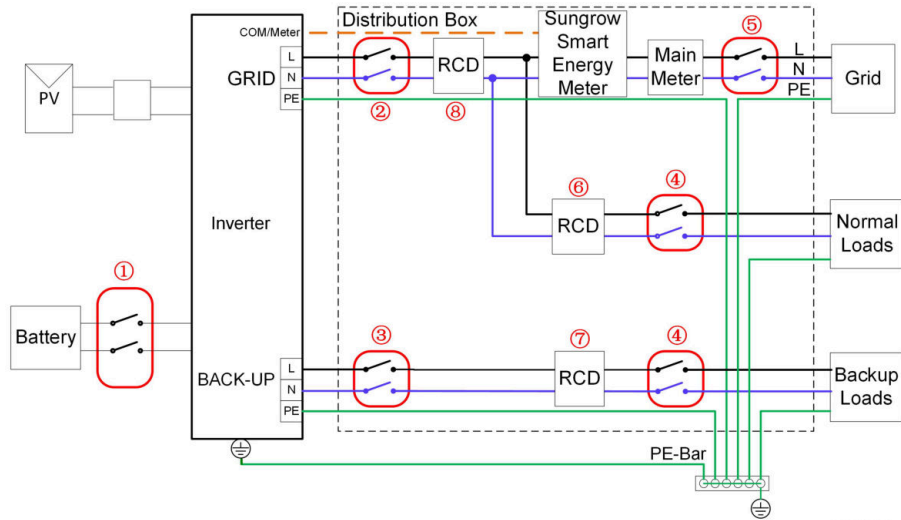

S007-E004

This wiring diagram is for reference only. Please confirm the actual wiring requirements for different regions with SUNGROW.

NO.	SH8.0/10RS
①	63A/600V DC breaker *
②	≤63A/230V/400V TypeC AC breaker
③	63A/230V/400V TypeC AC breaker
④	Depends on loads
⑤	Depends on household loads and inverter capacity (Optional)
⑥⑦	30mA RCD (Recommended)
⑧	300mA RCD (Recommended)

Note 1: * If the battery is integrated with a readily accessible internal DC breaker, no additional DC breaker is required.

Note 2: The recommended values in the table are for reference only. The actual values must comply with local standard and actual conditions.

Note 3: The rated current of breaker ② is suggested to lower than that of breaker ⑤.

Note 4: If the rated current of on-site power cables are lower than those recommended above, the breakers specification should be considered to match the power cables in first priority.

Note 5: The AC port takes power from the grid and is set according to the grid circuit breaker.

For TT system

In the TT system, the following diagram is an example for grid systems without special requirement on wiring connection.

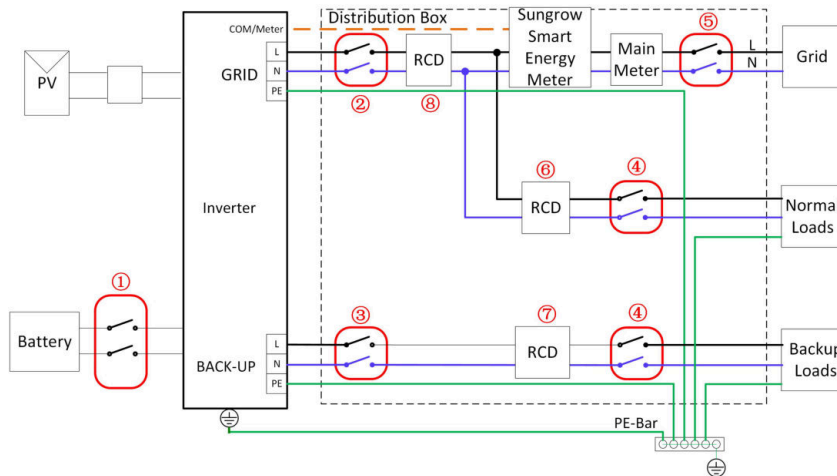

S007-E005

This wiring diagram is for reference only. Please confirm the actual wiring requirements for different regions with SUNGROW.

NO.	SH8.0/10RS
①	63A/600V DC breaker *
②	≤63A/230V/400V TypeC AC breaker
③	63A/230V/400V TypeC AC breaker
④	Depends on loads
⑤	Depends on household loads and inverter capacity (Optional)
⑥/⑦	30mA RCD (Recommended)
⑧	300mA RCD (Recommended)

Note 1: * If the battery is integrated with a readily accessible internal DC breaker, no additional DC breaker is required.

Note 2: The recommended values in the table are for reference only. The actual values must comply with local standard and actual conditions.

Note 3: The rated current of breaker ② is suggested to lower than that of breaker ⑤.

Note 4: If the rated current of on-site power cables are lower than those recommended above, the breakers specification should be considered to match the power cables in first priority.

Note 5: The AC port takes power from the grid and is set according to the grid circuit breaker.

Whole Home Backup

For AU/NZ/SA:

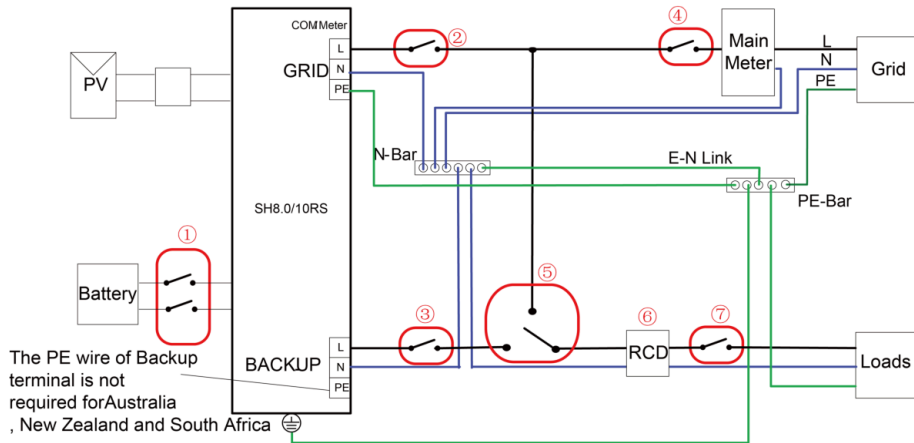

This wiring diagram is for reference only. Please confirm the actual wiring requirements for different regions with SUNGROW.

NO.	SH8.0/10RS
①	63A/600V DC breaker *
②	≤63A/230V/400V TypeC AC breaker
③	63A/230V/400V TypeC AC breaker
④	Depends on household loads and inverter capacity
⑤	63A/230V manual changeover switch
⑥	30mA RCD (Recommended)
⑦	Depends on loads

Note 1: * If the battery is integrated with a readily accessible internal DC breaker, no additional DC breaker is required.

Note 2: The recommended values in the table are for reference only. The actual values must comply with local standard and actual conditions.

6.5 External Protective Grounding Connection

⚠ DANGER

- There are large currents during the inverter's operation. If the inverter is powered on and put into operation without being grounded, it may lead to electric shock hazards or failures of major protective functions such as surge protection. Therefore, before powering on the inverter, make sure it has been reliably grounded; otherwise, damages caused therefrom will not be covered by warranty.
- When performing electrical connections of the inverter, give the highest priority to grounding. Be sure to carry out the grounding connection first.

⚠ WARNING

- Since the inverter is not equipped with a transformer, neither the negative electrode nor the positive electrode of the PV string can be grounded. Otherwise, the inverter will not operate normally.
- Connect the grounding terminal to the external protective grounding point before AC cable connection, PV string connection, and communication cable connection.
- The external protective grounding point provides a reliable ground connection. Do not use an improper grounding conductor for grounding, Otherwise, it may cause product damage or personal injury.
- Depending on Local Rules, please also ground the PV panel subconstruction to the same common grounding point (PE Bar) in addition to local lightning protection rules.

⚠ WARNING

The external protective grounding terminal must meet at least one of the following requirements.

- The cross-sectional area of the grounding cable is not less than 10 mm² for copper wire or 16 mm² for aluminum wire. It is recommended that both the external protective grounding terminal and the AC side grounding terminal be reliably grounded.
- If the cross-sectional area of the grounding cable is less than 10 mm² for copper wire or 16 mm² for aluminum wire, ensure that both the external protective grounding terminal and the AC side grounding terminal are reliably grounded.

The grounding connection can be made by other means if they are in accordance with the local standards and regulations, and SUNGROW shall not be held liable for the possible consequences.

6.5.1 External Protective Grounding Requirements

All non-current carrying metal parts and device enclosures in the PV power system should be grounded, for example, brackets of PV modules and inverter enclosure.

When there is only one inverter in the PV system, connect the external protective grounding cable to a nearby grounding point.

When there are multiple inverters in the PV system, connect the external protective grounding terminals of all inverters and the grounding points of the PV module brackets to ensure equipotential connections to ground cables (according to the onsite conditions).

6.5.2 Connection Procedure

Step 1 Prepare the cable and OT/DT terminal.

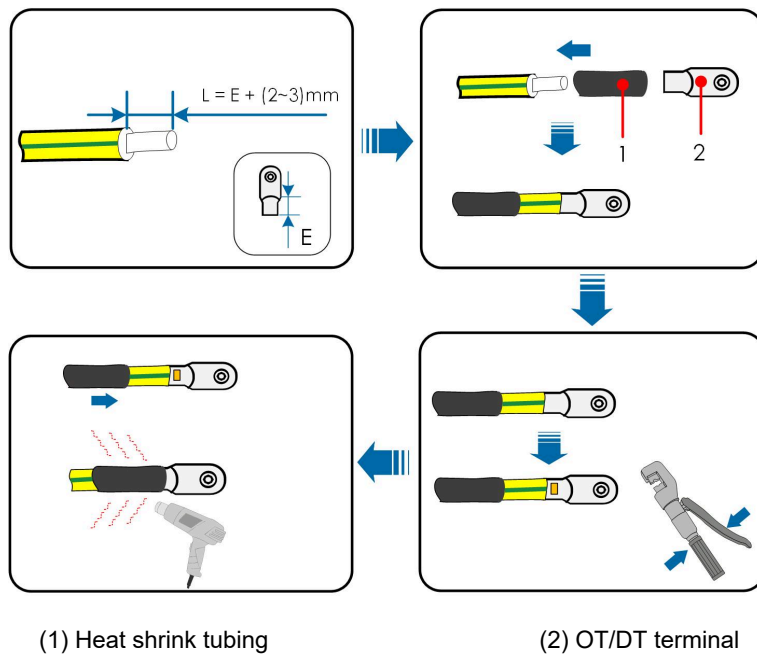

After being crimped, the OT terminal must wrap the wires completely, and the wires must contact the OT terminal closely.
When using a heat gun, protect the device from being scorched.

Step 2 Remove the screw on the grounding terminal and fasten the cable with a screwdriver.

Step 3 Apply paint to the grounding terminal to ensure corrosion resistance.

--End

6.6 AC Cable Connection

6.6.1 AC Side Requirements

Only with the permission of the local grid department, the inverter can be connected to the grid.

Before connecting the inverter to the grid, ensure the grid voltage and frequency comply with requirements, for which, refer to "**Technical Data**". Otherwise, contact the electric power company for help.

AC Circuit Breaker

An independent two-pole circuit breaker must be installed on the output side of the inverter to ensure safe disconnection from the grid. The recommended specifications are as follows.

WARNING

AC circuit breakers should be installed on the output side of the inverter and the grid side to ensure safe disconnection from the grid.

- **Determine whether an AC circuit breaker with greater overcurrent capacity is required based on actual conditions.**
- **Multiple inverters cannot share one AC circuit breaker.**
- **When a short circuit occurs and causes grid voltage drop, the peak short-circuit current of AC grid port and back-up port can be over 150A.**

Residual Current Monitoring Device

With an integrated universal current-sensitive residual current monitoring unit included, the inverter will disconnect immediately from the mains power once a fault current with a value exceeding the limit is detected.

However if an external residual current device (RCD) (type A is recommended) is mandatory, the switch must be triggered at a residual current of 300 mA (recommended). RCD of other specifications can also be used according to local standard.

6.6.2 Connecting the AC Cable

Step 1 Disconnect the AC circuit breaker and secure it against reconnection.

Step 2 Unscrew the swivel nut and take out the sealing ring.

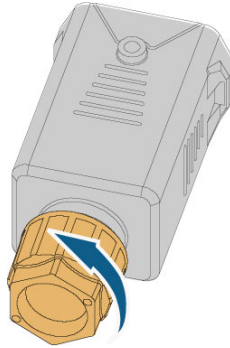

Step 3 Thread the AC cable through the swivel nut, appropriate sealing and waterproof cover in sequence.

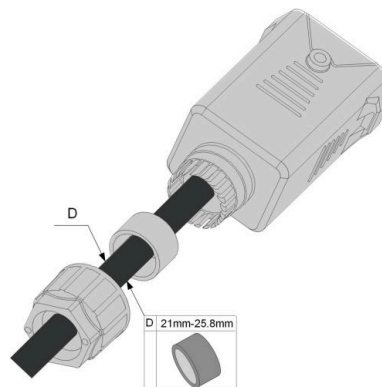

Step 4 Strip the cable jacket and the wire insulation as shown in the following figure.

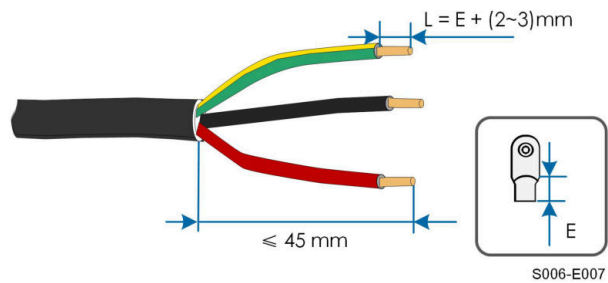

Step 5 Crimp the OT/DT terminal.

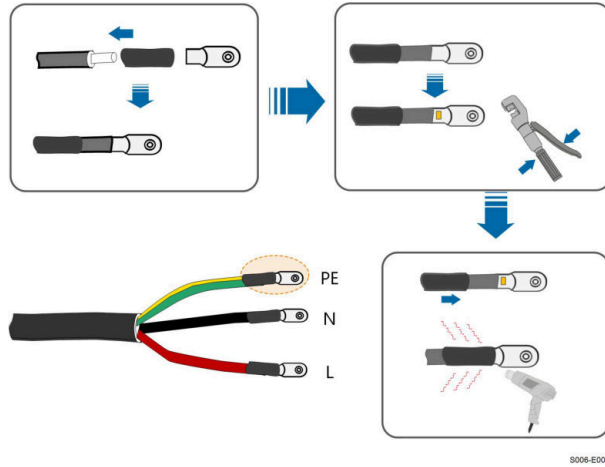

Step 6 Remove the waterproof lid from the **GRID** terminal.

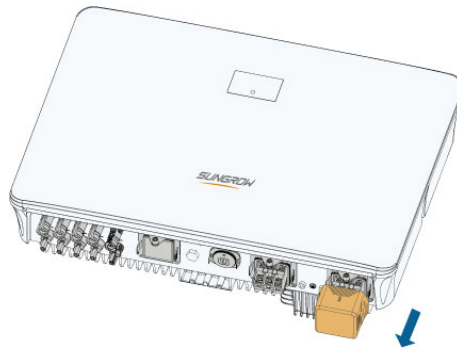

Step 7 Fix all the wires to the terminals according to the assignment and tighten to a torque of 2.0 N•m with a screwdriver.

NOTICE

Observe the terminal assignment. Do not connect any phase line to the "PE" terminal or PE wire to "N" terminal. Otherwise, unrecoverable damage to the inverter may follow.

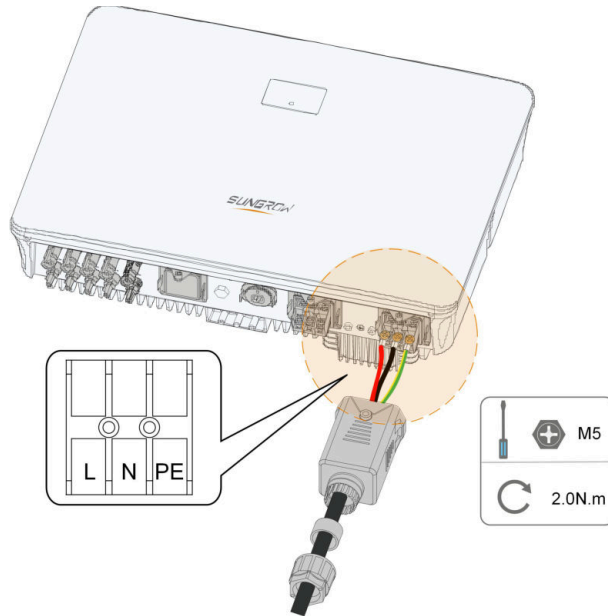

Step 8 Secure the AC waterproof cover to the inverter with a torque of 0.5 N•m and tighten the swivel nut to a torque of 5 N•m–6 N•m.

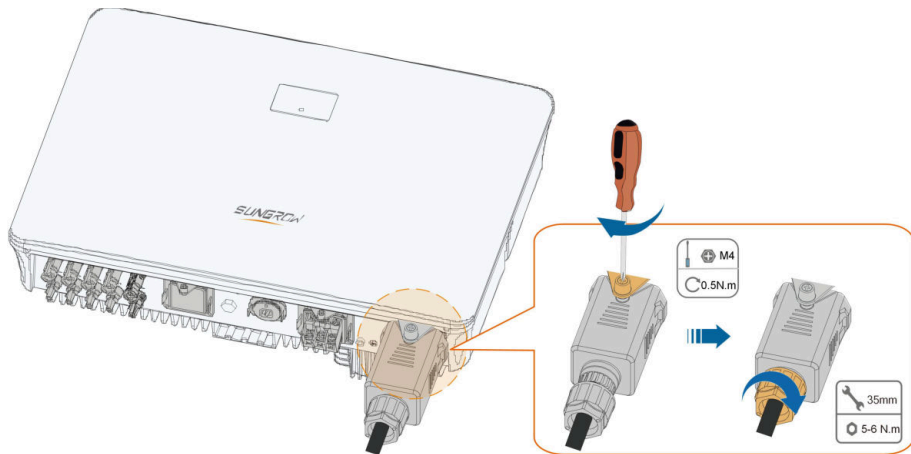

Step 9 Connect the PE wire to ground and the phase lines and the “N” line to AC circuit breaker. Then connect the AC circuit breaker to electric board.

Step 10 Make sure all wires are firmly installed via the right torque tool or dragging the cables slightly.

--End

6.7 DC Cable Connection

⚠ DANGER

The PV string will generate lethal high voltage when exposed to sunlight.

- Respect all safety instructions listed in relevant documents about PV strings.

⚠ WARNING

- Make sure the PV array is well insulated to ground before connecting it to the inverter.
- Make sure the maximum DC voltage and the maximum short circuit current of any string never exceed inverter permitted values specified in "Technical Data".
- Check the positive and negative polarity of the PV strings, and connect the PV connectors to corresponding terminals only after ensuring polarity correctness.
- During the installation and operation of the inverter, please ensure that the positive or negative electrodes of PV strings do not short-circuit to the ground. Otherwise, an AC or DC short-circuit may occur, resulting in equipment damage. The damage caused by this is not covered by the warranty.
- Electric arc or contactor over-temperature may occur if the DC connectors are not firmly in place, and the loss caused is not covered by the warranty.
- If the DC input cables are reversely connected or the positive and negative terminals of different MPPT are shorted to ground at the same time, while the DC switch is in the "ON" position, do not operate immediately. Otherwise, the inverter may be damaged. Please turn the DC switch to "OFF" and remove the DC connector to adjust the polarity of the strings when the string current is lower than 0.5 A.
- Use the DC connectors supplied with the product for DC cable connection. Using incompatible DC connectors may result in serious consequences, and the device damage is not covered under warranty.
- Do not connect one PV string to multiple inverters. Otherwise, the inverters may be damaged.

NOTICE

The following requirements about PV string connection must be met. Otherwise, it may cause irreversible damage to the inverter, which is not covered by the warranty.

- Mixed use of PV modules of different brands or models in one MPPT circuit, or PV modules of different orientation or inclination in a string may not damage inverter, but will cause system bad performance!

6.7.1 PV Input Configuration

- The inverters have four PV inputs, each with independent MPP tracker. Each DC input area can operate independently.
- The PV strings to four DC input areas may differ from each other, including PV module type, number of PV modules in each string, angle of tilt, and installation orientation.

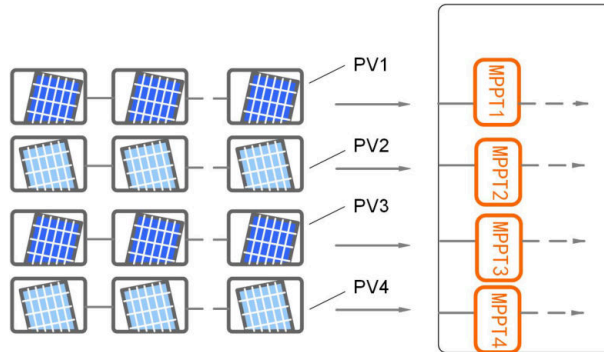

Figure 6-3 PV Input Configuration

- To enhance user convenience, a partial parallel mode for PV1 and PV2 has been added.

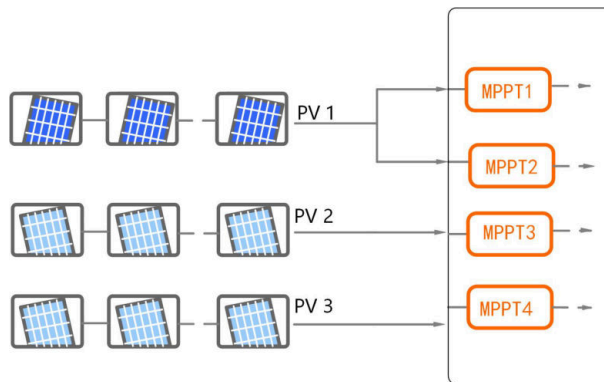

Figure 6-4 PV Input Configuration

Only the parallel connection method of MPPT as shown in the figure is supported. Other parallel methods are not currently supported.

Prior to connecting the inverter to PV inputs, the following electrical specifications must be met simultaneously:

Inverter Model	Open-circuit Voltage Limit	Max. Current for Input Connector
SH8.0/10RS	600 V	20 A

NOTICE

Take the SH10RS inverter for example:

1. Each MPPT works independently and when string operating voltage exceed 235V, it can get full load capacity of its MPPT.
2. When the string operating voltage is between 100V and 235V, there is no derating in normal case but higher heat could be generated under the situation of prolonged, high-temperature operation which may cause overheat derating.
3. When the string operating voltage is between 50V and 100V, PV input current will be derated with the voltage drop. i.e. 16A@100V; 8A @64V;

6.7.2 Assembling the PV Connectors**Prerequisite****⚠ DANGER**

High voltage may be present in the inverter!

- Ensure all cables are voltage-free before performing electrical operations.
- Do not connect the DC switch and AC circuit breaker before finishing electrical connection.

To ensure IP65 protection, use only the supplied connector.

Step 1 Strip the insulation from each DC cable by about 7 mm.

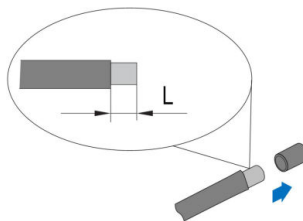

Step 2 Assemble the cable ends with the crimping pliers.

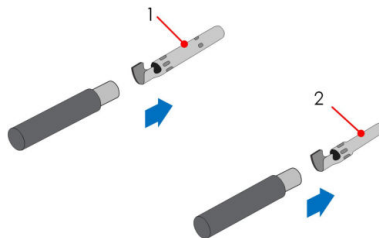

1: Positive crimp contact

2: Negative crimp contact

Step 3 Lead the cable through cable gland, and insert the crimp contact into the insulator until it snaps into place. Gently pull the cable backward to ensure firm connection. Tighten the cable gland and the insulator (torque 3.4 N.m to 3.5 N.m).



Step 4 Check for polarity correctness.

NOTICE

If the PV polarity is reversed, the inverter will be in a fault or alarm state and will not operate normally.

--End

6.7.3 Installing PV Connector

Step 1 Rotate the DC switch to "OFF" position.

Step 2 Check the cable connection of the PV string for polarity correctness and ensure that the open circuit voltage in any case does not exceed the inverter input limit of 600V.

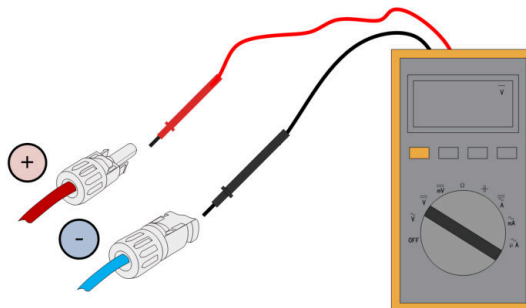

NOTICE

The multimeter must have a DC voltage range of at least 600 V. If the voltage is a negative value, the DC input polarity is incorrect. Please correct the DC input polarity. If the voltage is greater than 600 V, too many PV modules are configured to the same string. Please remove some PV modules.

Step 3 Connect the PV connectors to corresponding terminals until there is an audible click.

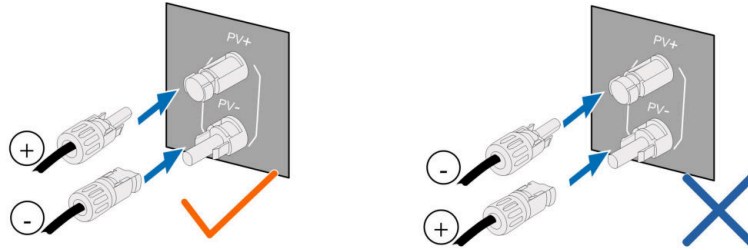

Step 4 Follow the foregoing steps to connect PV connectors of other PV strings.

Step 5 Seal any unused PV terminal with a terminal cap.

--End

6.8 Emergency Load Connection (Backup)

NOTICE

Risk of inverter damage due to incorrect cable connection. Do not connect the grid power wires to BACKUP port.

Observe the plug assignment.

- **Do not connect the L line to the "PE" terminal or the PE wire to the "N" terminal. Otherwise, unrecoverable damage to the inverter may follow.**
- **Do not connect the L line and the N line in reverse, otherwise the inverter may not operate normally.**

Do not short-circuit the Backup port during operation. Otherwise, the inverter or power distribution system will be seriously damaged. The loss is not covered by the SUNGROW warranty.

Step 1 If no emergency load is connected to the Backup terminal, be sure to insert the Backup connector into the terminal to ensure safety.

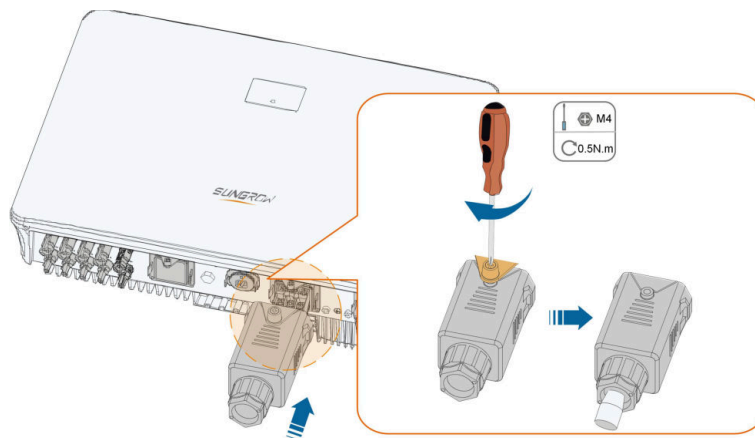

Step 2 Before connecting the emergency load to the Backup terminal, unscrew the swivel nut and take out the sealing ring first.

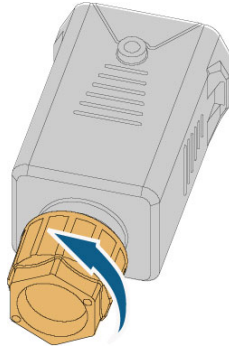

Step 3 Thread the BACKUP cable through the swivel nut, appropriate sealing and waterproof cover in sequence.



S006-E006

Step 4 Strip the cable jacket and the wire insulation as shown in the following figure.

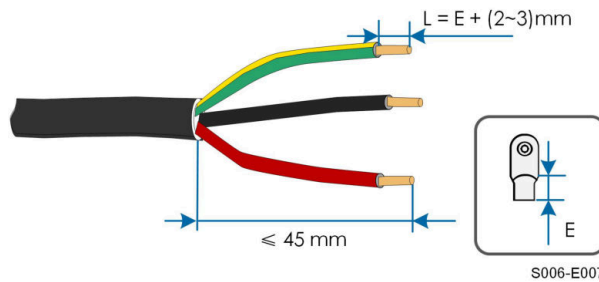

S006-E007

Step 5 Crimp the OT/DT terminal.

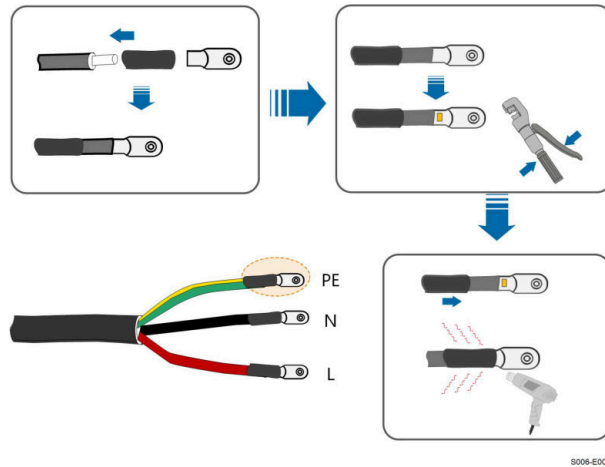

Step 6 Remove the waterproof lid from the **BACKUP** terminal.

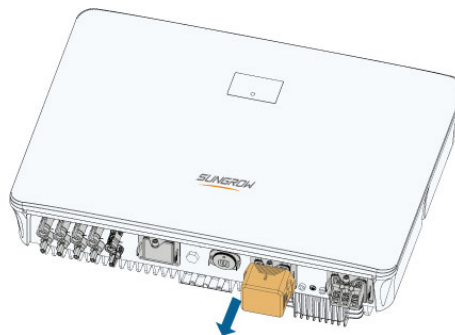

Step 7 Fix all the wires to the terminals according to the assignment and tighten to a torque of 2.0 N•m with a screwdriver.

NOTICE

Observe the terminal assignment. Do not connect any phase line to the "PE" terminal or PE wire to "N" terminal. Otherwise, unrecoverable damage to the inverter may follow.

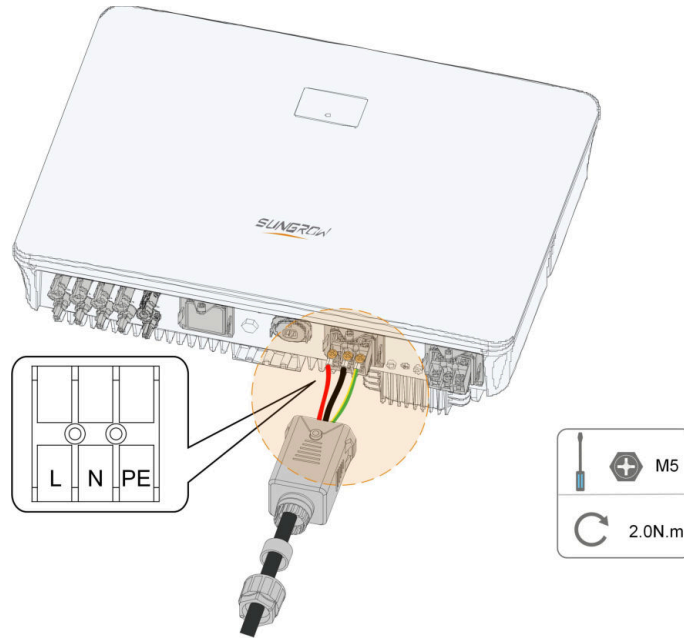

Step 8 Secure the BACKUP waterproof cover to the inverter with a torque of 0.5 N•m and tighten the swivel nut to a torque of 5 N•m–6 N•m.

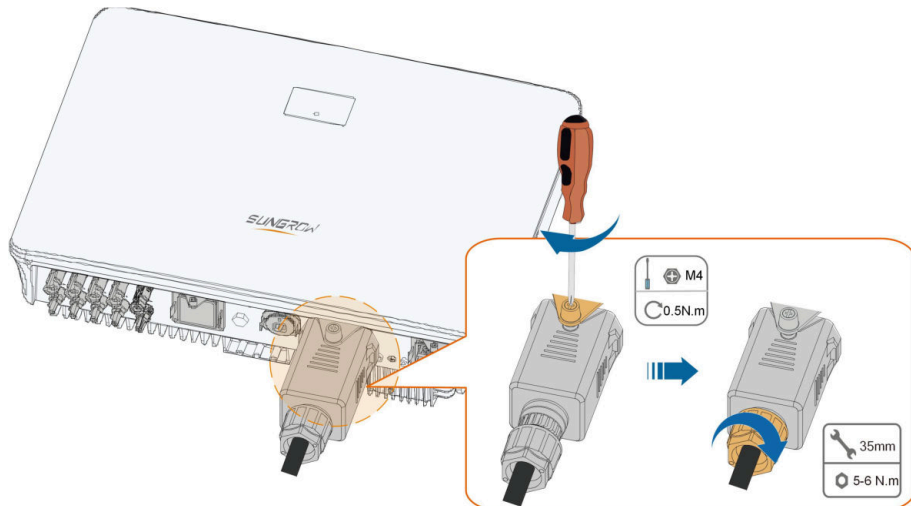

Step 9 Pull all the lines outward lightly to check whether they are firmly installed.

--End

6.9 Battery Connection

This section mainly describes the cable connections on the inverter side. Refer to the instructions supplied by the battery manufacturer for the connections on the battery side and configuration.

⚠ WARNING

Only use properly insulated tools to prevent accidental electric shock or short circuits. If insulated tools are not available, use electrical tape to cover the entire exposed metal surfaces of the available tools except their tips.

⚠ WARNING

The plug connector must be connected only by trained electricians.

⚠ WARNING

Do not disconnect under load!
Battery connectors must not be disconnected while under load. They can be placed in a no load state by shutting down the inverter completely.

⚠ WARNING

During the installation and operation of the inverter, please ensure that the positive or negative polarities of batteries do not short-circuit to the ground. Otherwise, an AC or DC short-circuit may occur, resulting in equipment damage. The damage caused by this is not covered by the warranty.

If the hybrid inverter is not connected to a battery, it will not support reliably the backup function.
The battery should be connected to the common grounding of the house (PE Bar) rather than directly to the inverter PE.
The energy in the battery will not backfeed into the PV modules.
The short-circuit current at the battery terminal of the inverter is 100A.

6.9.1 Installing the Battery Connector

Prerequisite

NOTICE

- When making the connections, always observe the specifications regarding nominal voltage and nominal current. The smallest common value is permissible.
- Battery DC switch is in the "OFF" position.

Step 1 Strip the insulation from each DC cable by 7–8 mm.

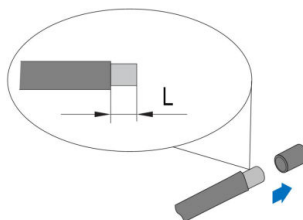

Step 2 Assemble the cable ends with the crimping pliers.

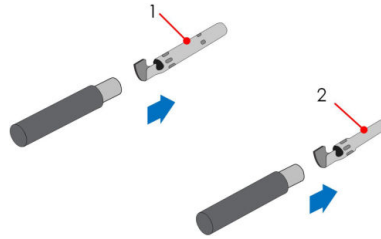

1: Positive crimp contact

2: Negative crimp contact

Step 3 Lead the cable through cable gland, and insert the crimp contact into the insulator until it snaps into place. Gently pull the cable backward to ensure firm connection.

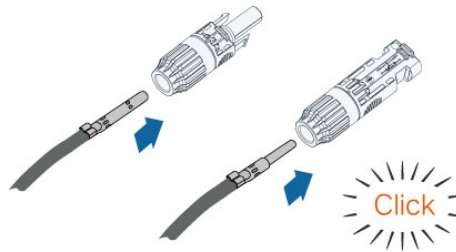

Step 4 Tighten the cable gland and the insulator.

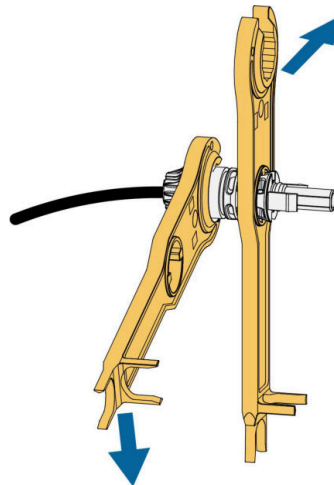

Step 5 Check for polarity correctness.

Step 6 Plug the connectors into **BAT+** and **BAT-** terminals.

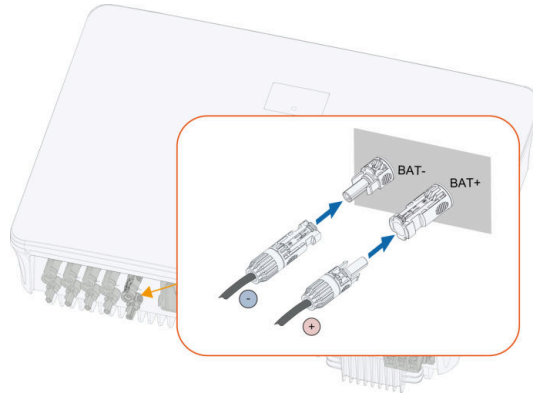

Step 7 Ensure that the connectors are securely in place.

The installation distance between the battery and the inverter < 30m.

--End

6.10 Communication Connection

WLAN function

LAN function

Through the Modbus TCP/IP protocol, the EMS or the Logger from the third party can fully control the on/off, derating, charging and discharging of the inverter.

RS485 function

The RS485 communication interfaces are used to establish communication connection with monitoring devices.

6.10.1 WiNet-S2/EyeM4 Connection

The WiNet-S2 module supports Ethernet communication and WLAN communication. It is not recommended to use both communication methods at the same time.

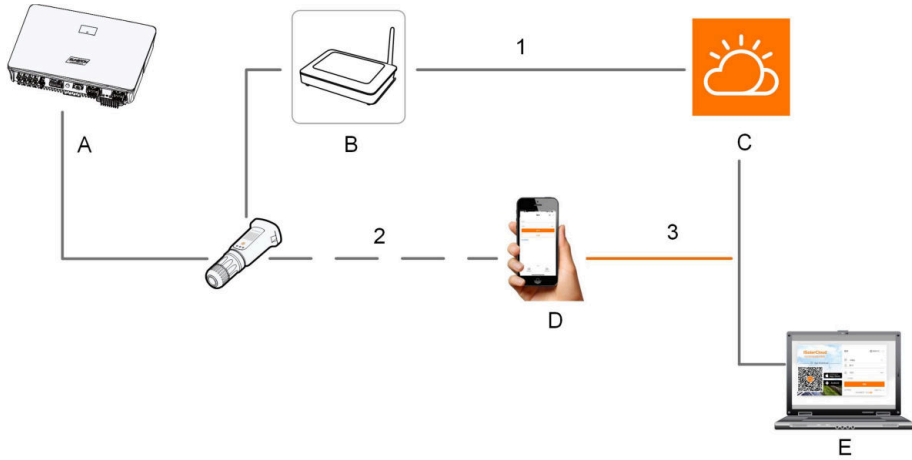

- (A) Inverter
- (B) Router/Switch
- (C) iSolarCloud server
- (D) iSolarCloud App
- (E) iSolarCloud
- (1) ——— Internet
- (2) - - - - Local access
- (3) ——— Remote

For details, see the quick guide for the WiNet-S2 module. Scan the following QR code for the quick guide.



EyeM4:

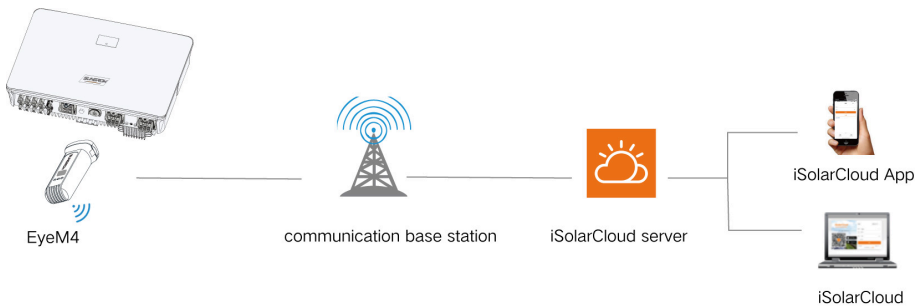

For details, see the quick guide for the EyeM4 module. Scan the following QR code for the quick guide.



6.10.1.1 Ethernet Communication

Step 1 (Optional) Strip the insulation layer of the communication cable with an Ethernet wire stripper, and lead the corresponding signal cables out. Insert the stripped communication cable into the RJ45 plug in the correct order, and crimp it with a crimper.

1: RJ45 plug

2: Protective cap

Skip this step if a standard network cable with RJ45 plug is prepared.

Step 2 Unscrew the swivel nut from the communication module and take out the inner sealing ring.

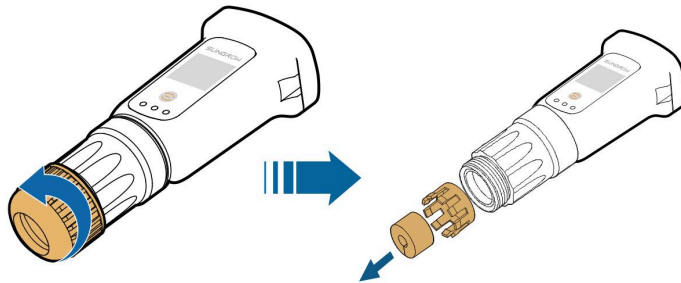

Step 3 Unscrew the housing from the communication module.

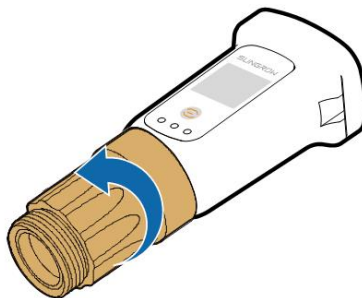

Step 4 Thread the network cable through the swivel nut and gasket. Afterwards, route the cable into the opening of the sealing. Finally, insert the cable through the housing.

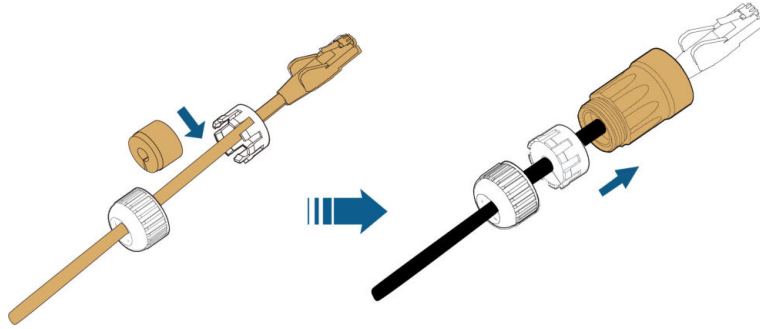

Step 5 Insert the RJ45 plug into the front plug connector until there is an audible click and tighten the housing. Install the gasket and fasten the swivel nut.

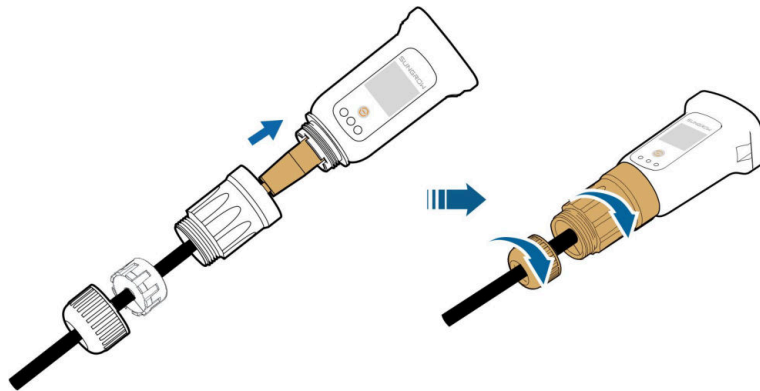

Step 6 Remove the waterproof lid from the terminal and install WiNet-S2.

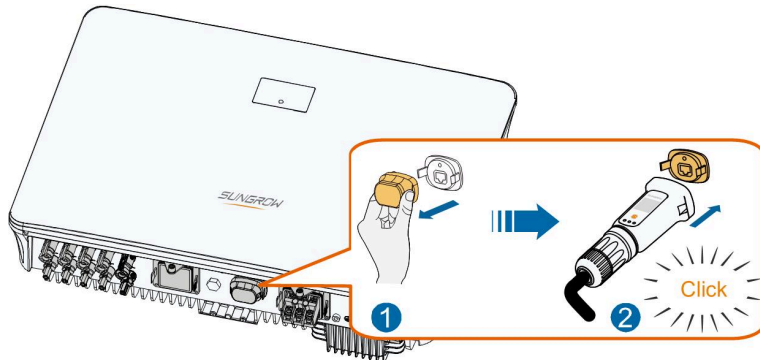

Step 7 Slightly shake it by hand to determine whether it is installed firmly.

--End

6.10.1.2 WLAN Communication

Step 1 Remove the waterproof lid from the **COM1** terminal.

Step 2 Install the module. Slightly shake it by hand to determine whether it is installed firmly, as shown below.

WiNet-S2

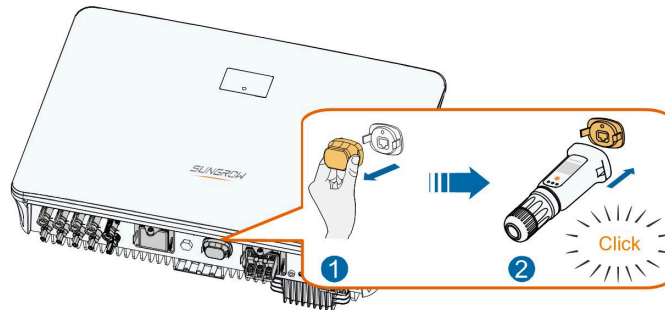

EyeM4

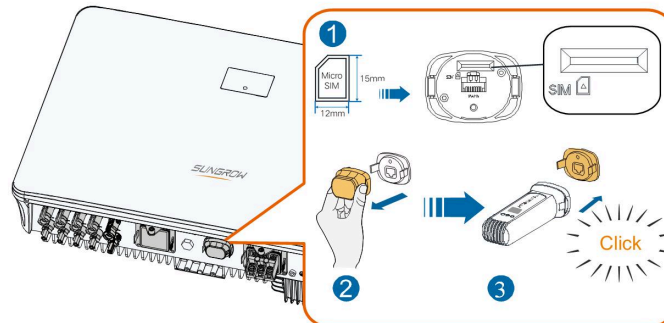

Step 3 Refer to the guide delivered with the module for the set-up.

--End

6.10.2 COM2 Terminal Connection

6.10.2.1 Meter Connection

The inverter can provide export control but will require the use of an external smart meter.

The Smart Energy Meter DTSU666–20 is used (provided in the box), please connect Pin A on the meter to A2 (Pin 3) on the inverter and Pin B on the meter to B2 (Pin 4) on the inverter.

- Contact SUNGROW to ensure that the Smart Energy Meter model is available locally.
- The energy meter is mainly used to detect the direction and magnitude of the current. And the energy meter data may not be used for billing purposes.
- The S100 meter displays only the absolute value of reactive power and does not indicate the direction.
- The inverter is equipped with the feed-in power limit function, so as to meet the requirements of some national standards or grid standards for the output power at the grid connection point.

NOTICE

- When wiring, make sure the arrow on the CT points in the direction from Grid to Load.
- Please refer to the CT ratio setting values in the table below to select the CT that matches the DTSU666-20 meter.

Setting Value	Matching CT
1	100 A/333 mV
2	250 A/333 mV

Smart Energy Meter Wiring Diagram

The Smart Energy Meter wiring diagram is presented as follows:

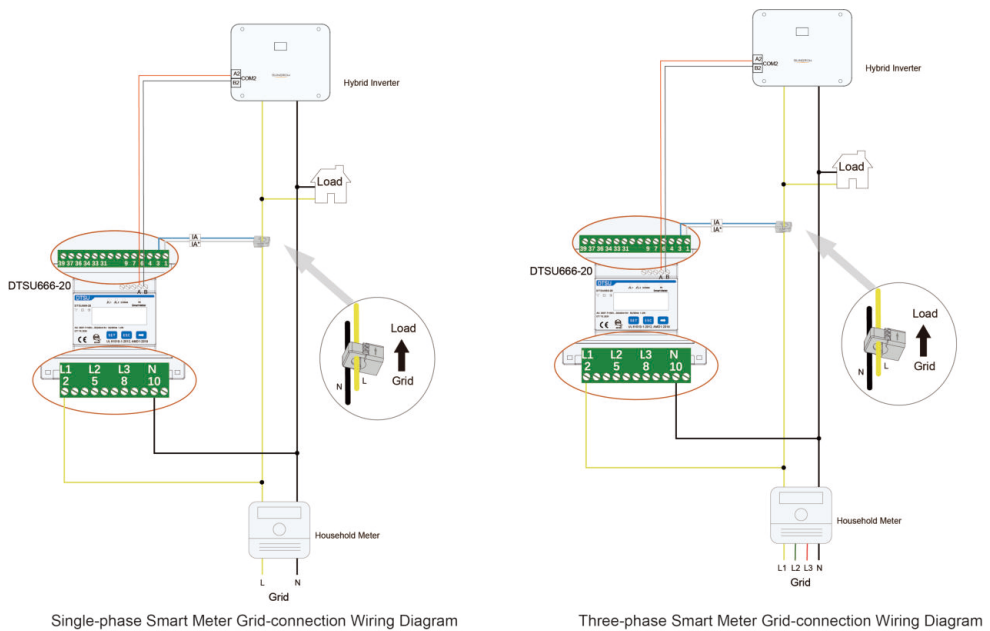

Step 1 Remove the cable jacket and strip the wire insulation.

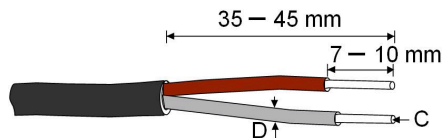

$$C = 0.5 - 1.0 \text{ mm}^2 \quad D \leq 2.8 \text{ mm}$$

S007-E044

Step 2 (Optional) When using a multi-strand wire cable, connect the wire head to the cord end terminal. In case of single-strand copper wire, skip this step.

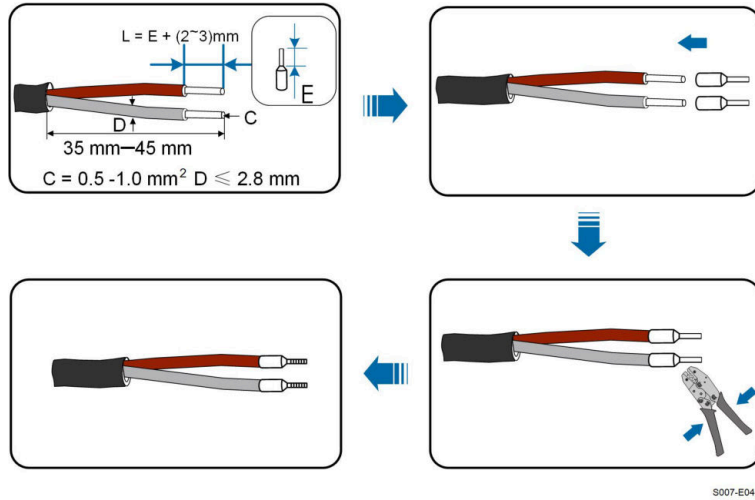

Step 3 Unscrew the swivel nut from the connector.

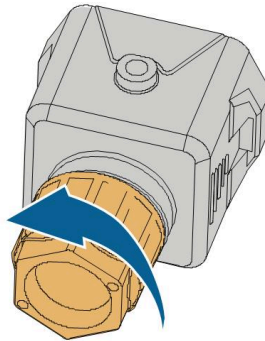

Step 4 Remove the seal and route the cable into the opening of the sealing.

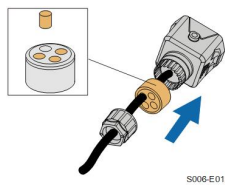

Step 5 Plug the wires into the corresponding terminals as shown in the following figure. Ensure that the wires are securely in place by slightly pulling them.

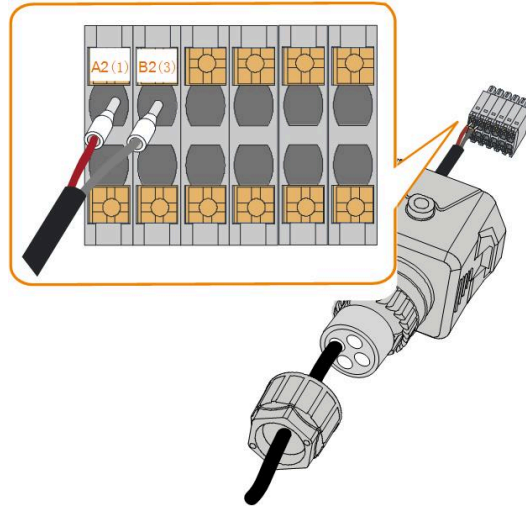

Step 6 Remove the waterproof lid from the **COM2** terminal.

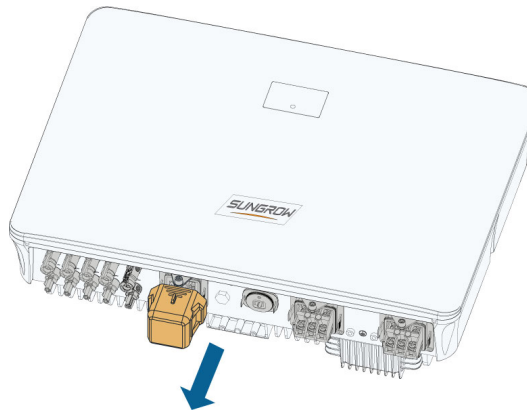

Step 7 Insert the terminal plug into the **COM2** terminal at the bottom side of the inverter and then install the housing.

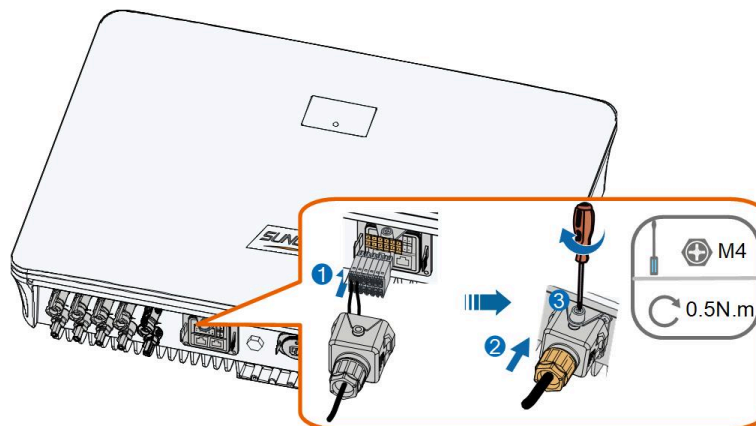

Step 8 Slightly pull out the cable and then fasten the swivel nut. Lock the connector with the screw.

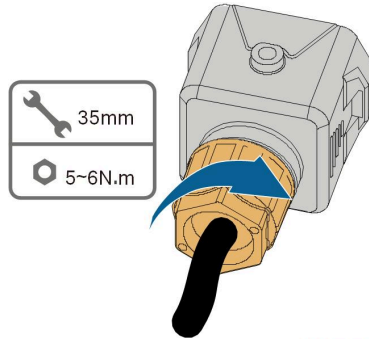

S006-E015

Step 9 The other end of the communication cable is connected to the A and B ports of the smart meter. If the smart energy meter is used, please refer to the following wiring method.

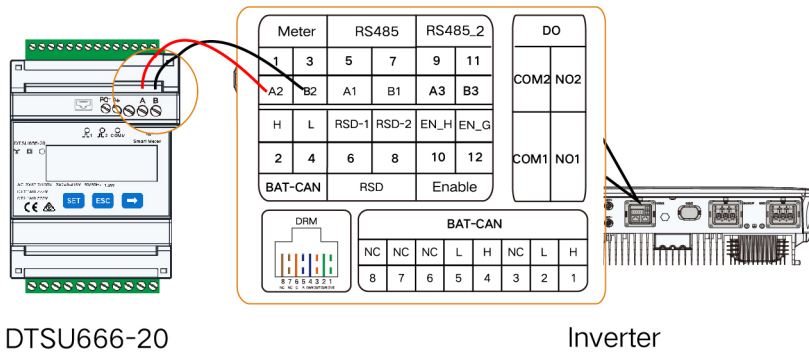

DTSU666-20

Inverter

Step 10 If the single-phase meter is used, please refer to the following wiring method.

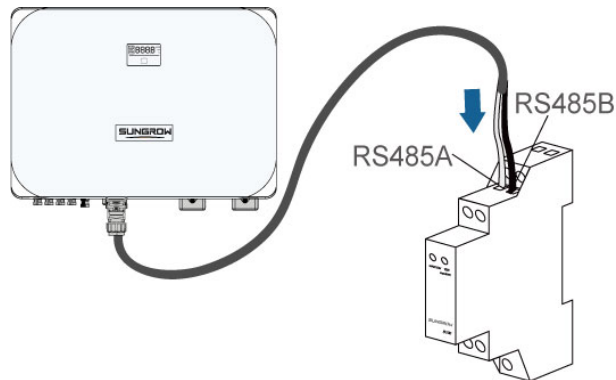

Step 11 (Optional) If the length of the communication cable > 10m, please connect a 120Ω resistor in parallel to the meter. Plug the resistor directly into both RS485 communication ports.

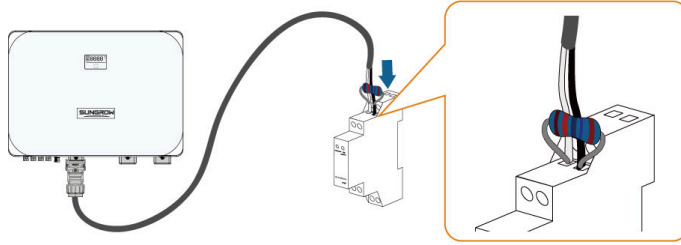

--End

6.10.2.2 Battery Communication Connection

The battery communication method can be used in the following two ways. For detailed connection description, refer to the section [6.10.2.1 Meter Connection](#)

Pin terminal connection

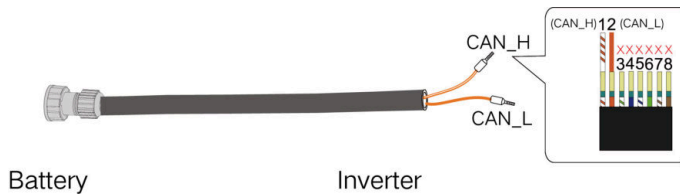

Battery

Inverter

The battery communication cable is connected to the inverter COM2 ports H and L.

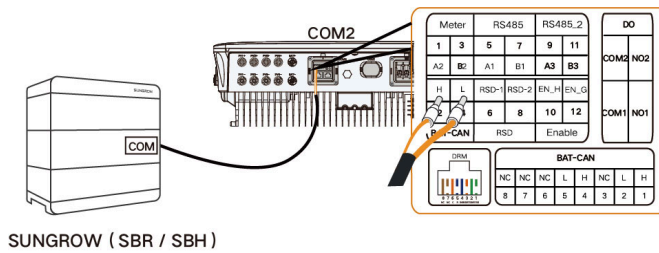

SUNGROW (SBR / SBH)

RJ45 connection



Battery

Inverter

The battery communication cable is connected to the inverter COM2 ports RJ45-CAN.

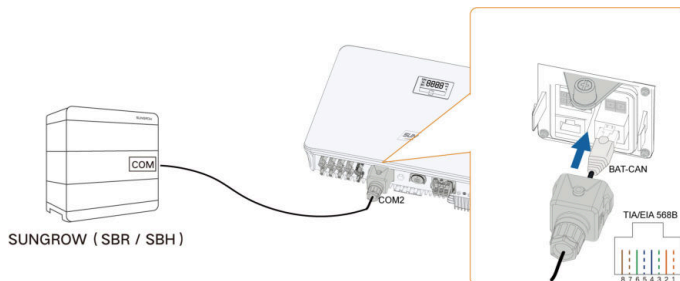

SUNGROW (SBR / SBH)

6.10.2.3 DRM Connection

DRM and Ripple Control support only one function at the same time.

DRM

In Australia and New Zealand, the inverter supports the demand response modes as specified in the standard AS/NZS 4777.

The following figure shows the wiring between the inverter and the external DRED.

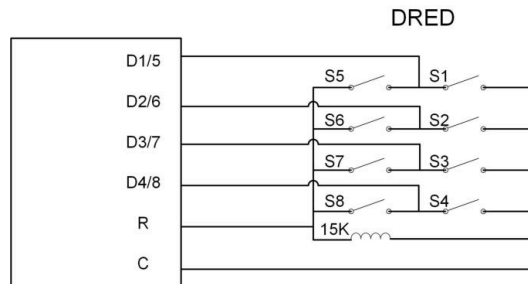
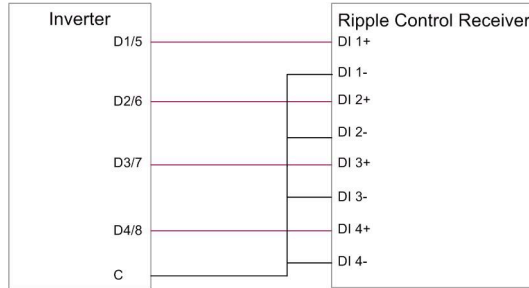

Table 6-4 Method of Asserting DRM

Mode	Asserted by Shorting Terminals on Inverter	Switch Operation on External DRED
DRM0	R & C	Close S1 and S5
DRM1	D1/5 & C	Close S1
DRM2	D2/6 & C	Close S2
DRM3	D3/7 & C	Close S3
DRM4	D4/8 & C	Close S4
DRM5	D1/5 & R	Close S5
DRM6	D2/6 & R	Close S6
DRM7	D3/7 & R	Close S7
DRM8	D4/8 & R	Close S8

Ripple Control

Wiring of the ripple control receiver dry contact cables is shown in the figure below:



Step 1 (Optional) Strip the insulation layer of the communication cable with an Ethernet wire stripper, and lead the corresponding signal cables out. Insert the stripped communication cable into the RJ45 plug in the correct order, and crimp it with a crimper.

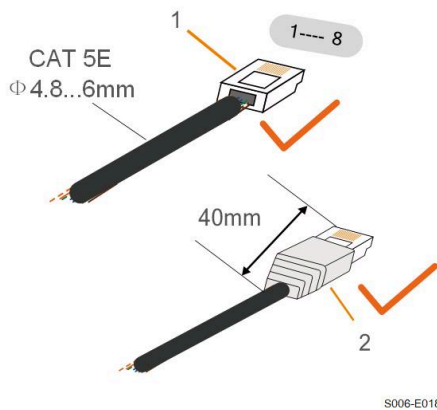

Skip this step if a standard network cable with RJ45 plug is prepared.

Step 2 Unscrew the swivel nut from the connector.

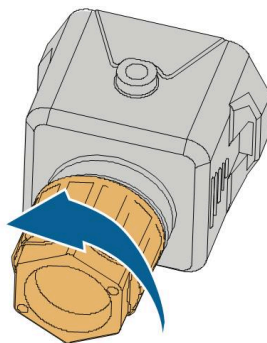

S006-E011

Step 3 Remove the seal.

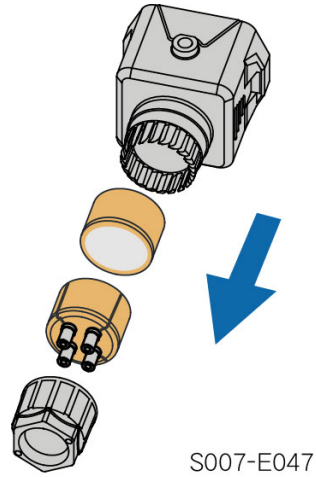

Step 4 Lead the cable through the cable gland.

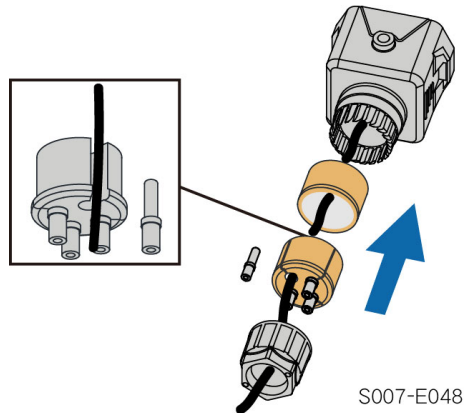

Step 5 Plug the wires into the corresponding terminals as shown in the following figure. Ensure that the wires are securely in place by slightly pulling them.

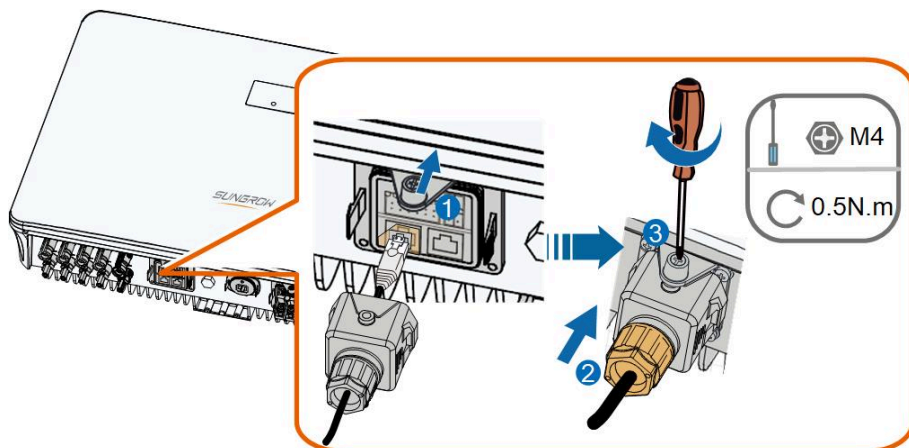

Step 6 Slightly pull out the cable and then fasten the swivel nut. Lock the connector with the screw.

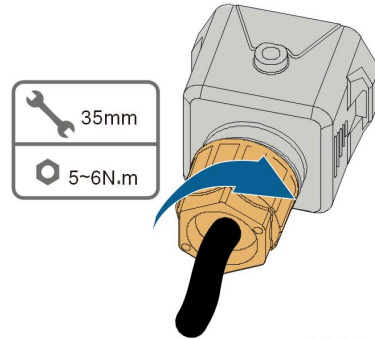

S006-E015

--End

6.11 DO Connection

The inverter has one DO relay with multiple functions as follows:

DO(COM1, NO1):

- Consumer load control. In this case the DO relay will control a contactor that will open or close in certain condition. Please choose the appropriate contactor according to the load power, e.g. the contactor types of the 3TF30 series from SIEMENS (3TF30 01-0X).
- Earth fault alarm. In this case, the additional equipment required is a light indicator and/or a buzzer.

DO(COM2, NO2):

- For further details on the DO wiring between the inverter and the generator, please refer to the Multi-Hybrid System Application Manual.

Relay	Trigger condition	Description
Consumer load control	The load control mode has been set via the iSolarCloud App.	The relay is activated once the conditions of the control mode are satisfied.
Earth fault alarm	The earth fault occurs.	Once the inverter receives the earth fault signal, the relay closes the contact. The relay remains triggered until the fault is removed.

The hybrid inverter provides two control modes based on the port on the smart load.

Mode 1: Prepare an additional DC source and an external relay. Choose the proper contact capacity of the external relay according to the port on the smart load. Use the DC source to drive the relay.

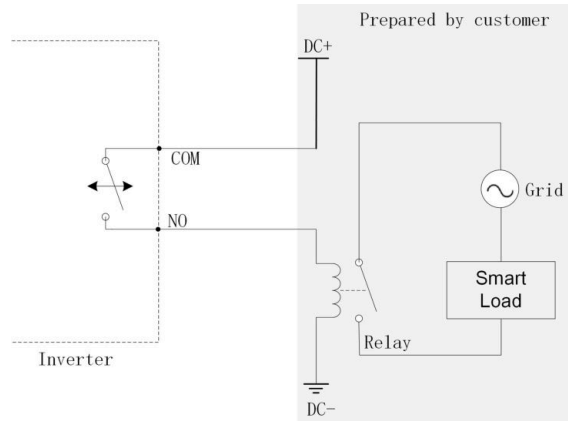

Mode 2: Use DO dry contacts to directly drive the smart load that has integrated a DI port. The maximum contact capacity of the DO dry contacts is 30 V DC@3 A.

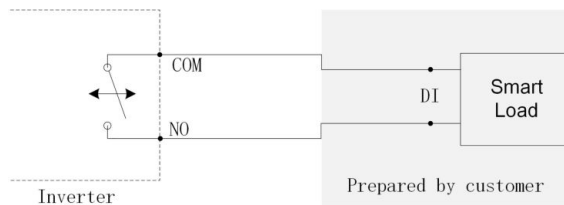

NOTICE

- The current of the DO dry contact should not be larger than 3 A.
- The DO mode is not controlled once the inverter is powered off. Connect the AC contactor by the manual switch, so as to control the loads.

6.12 Protective Cover Installation (Optional)

NOTICE

- Please install the protective cover after finishing all electrical connections of the inverter.

The installation procedure of the protective cover is as follows:

Step 1 The protective cover consists of a left cover, a right cover and a top cover.

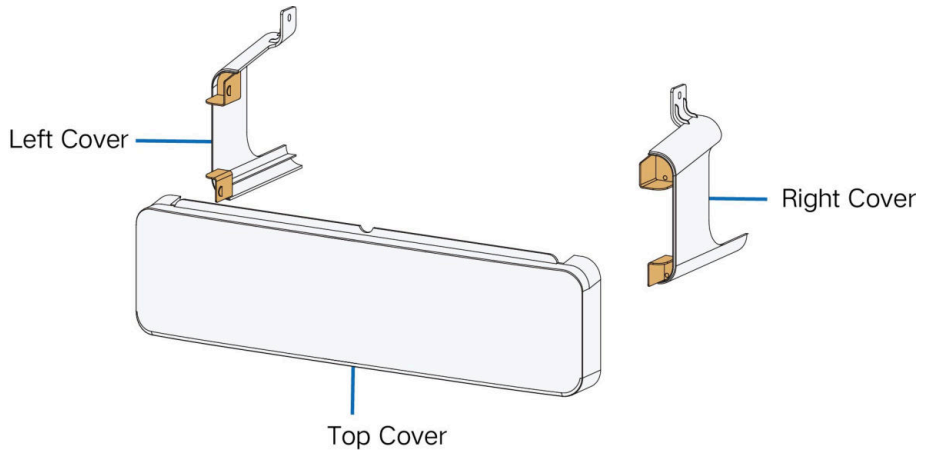

Step 2 Slot the left cover and the right cover into the top cover until there is an audible "click".

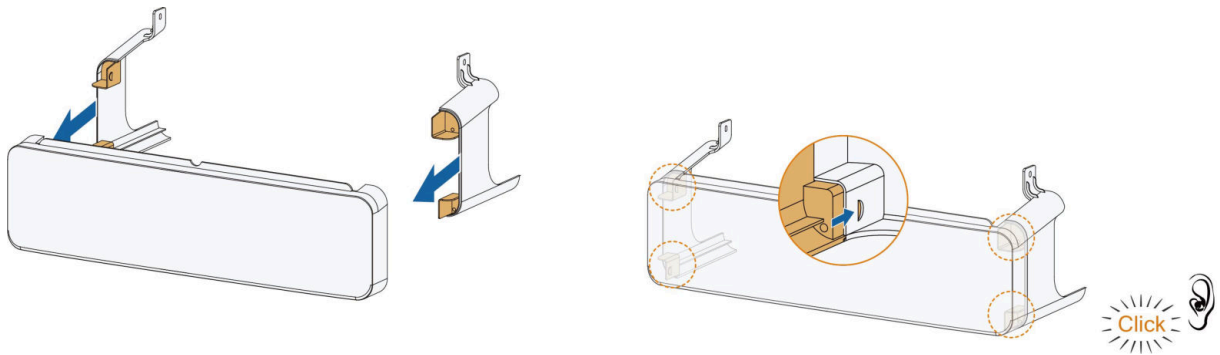

Step 3 After the electrical connection of the inverter is completed, install the protective cover to the inverter bottom and make sure that the threaded holes in buckles of the protective cover are aligned with the holes on the sides of the inverter.

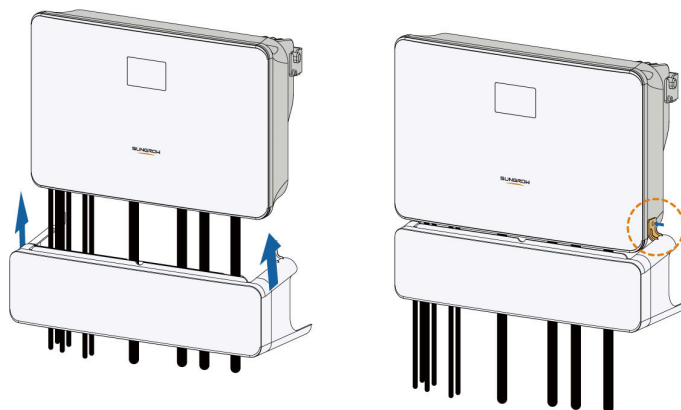

Step 4 Use a screwdriver to secure screws with a torque of 1.5 N.m.

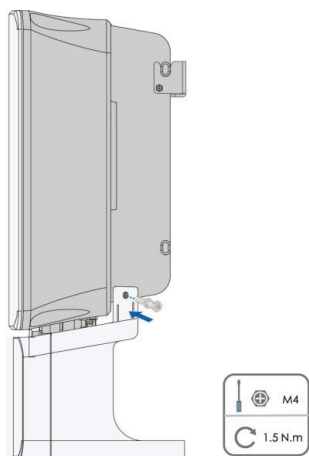

Step 5 The installation of the protective cover is completed.

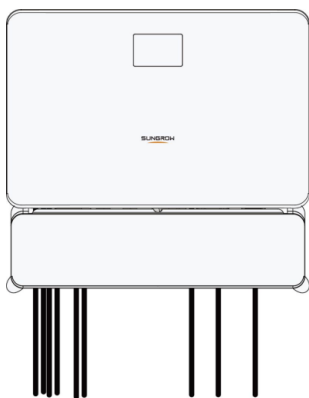

--End

7 Commissioning

7.1 Inspection Before Commissioning

Check the following items before starting the inverter:

- All equipment has been reliably installed.
- DC switch(es) and AC circuit breaker are in the "OFF" position.
- The ground cable is properly and reliably connected.
- The AC cable is properly and reliably connected.
- The DC cable is properly and reliably connected.
- The communication cable is properly and reliably connected.
- The unused terminals are sealed.
- No foreign items, such as tools, are left on the top of the machine or in the junction box (if there is).
- The AC circuit breaker is selected in accordance with the requirements of this manual and local standards.
- All warning signs & labels are intact and legible.

7.2 Powering on the System

Prerequisite

If all of the items mentioned above meet the requirements, proceed as follows to start up the inverter for the first time.

- Step 1** Turn on the AC circuit breaker between the inverter and the grid.
- Step 2** (Optional) Connect the external DC circuit breaker between the inverter and the battery pack if a battery is equipped.
- Step 3** (Optional) Power on the battery pack manually if a battery is equipped.
- Step 4** Rotate the DC switch of the inverter to "ON" position.
- Step 5** If the irradiation and grid conditions meet requirements, the inverter will operate normally. Observe the LED indicator to ensure that the inverter operates normally. Refer to [2.4 LED Panel](#) for LED screen introduction and LED indicator definition.
- Step 6** Refer to the quick guide for WiNet-S2/EyeM4 for its indicator definition.

--End

8 iSolarCloud App

8.1 About iSolarCloud

The iSolarCloud App is a mobile application used for power plant management. The App provides plant operation analysis service and enables intelligent mobile O&M. It is designed with functions such as plant operation data display, rapid plant access, parameter setting, quick fault location and notification, and power yield and revenue analysis. With iSolarCloud, convenient and efficient end-to-end plant O&M is allowed.

Connection Methods

Users can log in to the App via remote connection or local access for plant monitoring.

Login by Establishing a Direct Connection (Local)

Establish communication between the mobile phone and the WiFi wireless communication module or the inverter's built-in Bluetooth module to enable mobile maintenance of the inverter. After logging into the App, users can check the information about and set parameters for the inverter.



Direct Login (Local)

Login via Bluetooth connection is applicable only for SUNGROW inverters with built-in Bluetooth modules. Please consult your retailer/installer about whether the inverter is equipped with a Bluetooth module.

Login with an Account (Remote)

Establish communication between the communication module and the home router or base station to enable data exchange between the inverter and the cloud server. After logging

into the App, users can check the inverter data or send commands to control the inverter on the App.

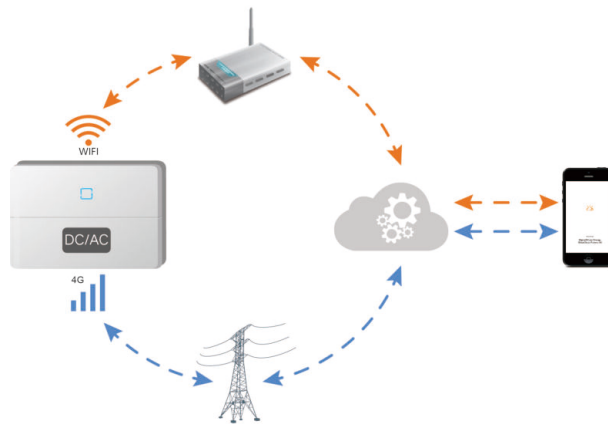

Login Via Account and Password (Remote)

8.2 Install iSolarCloud

Prerequisite

This section introduces how to download and install the iSolarCloud App.

Procedure

Step 1 Search for **iSolarCloud** in App Store, Google Play or other App stores, or scan the QR code below with a mobile phone and download the App by following the onscreen instructions.



Step 2 Tap the downloaded installation package and follow the onscreen instructions to complete the installation. The icon of iSolarCloud will then appear on the screen.



--End

8.3 User Roles

After logging into the iSolarCloud App with different roles, users will have varying levels of access to device operations. The default accounts and passwords corresponding to different user roles can be found in [iSolarCloud App User Manual Device Commissioning \(V2.1.6.20250218or Later\) > Device Connection > Device Connection via WLAN > Identity Verification](#).

For account security purposes, please refer to the **Identity Verification** section to change your password promptly after logging into the iSolarCloud App.

8.4 Device Commissioning

For device commissioning operations, please refer to the **Device Commissioning** in the [iSolarCloud App User Manual](#). Alternatively, you can scan the QR code below to access the **Device Commissioning** section of the manual.



9 System Decommissioning

9.1 Decommissioning the Inverter

9.1.1 Disconnecting the Inverter

Prerequisite

⚠ CAUTION

Danger of burns!

Even if the inverter is shut down, it may still be hot and cause burns. Wear protective gloves before operating the inverter after it cools down.

For maintenance or other service work, the inverter must be switched off. Proceed as follows to disconnect the inverter. Lethal voltages or damage to the inverter will follow if otherwise.

Step 1 Disconnect the external AC circuit breaker and prevent it from inadvertent reconnection.

Step 2 Rotate the DC switch to the "OFF" position for disconnecting all of the PV string inputs.

Step 3

Step 4 Wait about minutes until the capacitors inside the inverter completely discharge.

Step 5 Ensure that the DC cable is current-free with a current clamp.

--End

9.1.2 Dismantling the Inverter

Prerequisite

⚠ CAUTION

Risk of burn injuries and electric shock!

Do not touch any inner live parts until for at least 10 minutes after disconnecting the inverter from the utility grid and the PV input.

Before dismantling the inverter, disconnect both AC and DC connections.

Step 1 Refer to [6 Electrical Connection](#) for the inverter disconnection of all cables in reverse steps.

Step 2 Dismantle the inverter referring to [5 Mechanical Mounting](#) in reverse steps.

Step 3 If necessary, remove the wall-mounting bracket from the wall.

Step 4 If the inverter will be reinstalled in the future, please refer to [4.3 Inverter Storage](#) for a proper conservation.

--End

9.1.3 Disposal of Inverter

Users take the responsibility for the disposal of the inverter.

⚠ WARNING

Please scrap the inverter in accordance with relevant local regulations and standards to avoid property losses or casualties.

NOTICE

Some parts of the inverter may cause environmental pollution. Please dispose of them in accordance with the disposal regulations for electronic waste applicable at the installation site.

9.2 Decommissioning the Battery

Prerequisite

Decommission the battery in the system after the inverter is decommissioned. Proceed as follows to decommission a Li-ion battery.

- Step 1** Disconnect the DC circuit breaker between the battery and the inverter.
- Step 2** Disconnect the communication cable between the battery and the inverter.
- Step 3** Wait for about 1 minute and then use the multimeter to measure the port voltage of the battery.
- Step 4** If the battery port voltage is zero, disconnect the power cables from the battery module.

--End

For disposal of this product, please call the phone number listed in the warranty booklet provided at the time of purchase.

10 Troubleshooting and Maintenance

10.1 Troubleshooting

Once the inverter fails, the fault information can be displayed on the App interface. If the inverter is equipped with an LCD screen, the fault information can be viewed on it.

The fault codes and troubleshooting methods of all Hybrid inverters are detailed in the table below. The device you purchase may only contain some of the fault information, and when the inverter fails, you can check the corresponding information through the fault codes from the mobile App.

Alarm ID	Alarm Name	Corrective Measures
2, 3, 14, 15	Grid Overvoltage	Generally, the inverter will be reconnected to the grid after the grid returns to normal. If the fault occurs repeatedly: 1. Measure the actual grid voltage, and contact the local electric power company for solutions if the grid voltage is higher than the set value. 2. Check whether the protection parameters are appropriately set via the App or the LCD. Modify the overvoltage protection values with the consent of the local electric power operator. 3. If the fault still exists, contact SUNGROW.
4, 5	Grid Undervoltage	Generally, the inverter will be reconnected to the grid after the grid returns to normal. If the fault occurs repeatedly: 1. Measure the actual grid voltage, and contact the local electric power company for solutions if the grid voltage is lower than the set value. 2. Check whether the protection parameters are appropriately set via the App or the LCD. 3. Check whether the AC cable is firmly in place. 4. If the fault still exists, contact SUNGROW.
8	Grid Overfrequency	Generally, the inverter will be reconnected to the grid after the grid returns to normal. If the fault occurs repeatedly:
9	Grid Underfrequency	1. Measure the actual grid frequency, and contact the local electric power company for solutions if the grid frequency is beyond the set range.

Alarm ID	Alarm Name	Corrective Measures
		<ol style="list-style-type: none"> 2. Check whether the protection parameters are appropriately set via the App or the LCD. 3. If the fault still exists, contact SUNGROW.
10	Grid Power Outage	<p>Generally, the inverter will be reconnected to the grid after the grid returns to normal. If the fault occurs repeatedly:</p> <ol style="list-style-type: none"> 1. Check whether the grid supplies power reliably. 2. Check whether the AC cable is firmly in place. 3. Check whether the AC cable is connected to the correct terminal (whether the live wire and the N wire are correctly in place). 4. Check whether the AC circuit breaker is connected. 5. If the fault still exists, contact SUNGROW.
12	Excess Leakage Current	<ol style="list-style-type: none"> 1. The fault can be caused by poor sunlight or damp environment, and generally the inverter will be reconnected to the grid after the environment is improved. 2. If the environment is normal, check whether the AC and DC cables are well insulated. 3. If the fault still exists, contact SUNGROW.
13	Grid Abnormal	<p>Generally, the inverter will be reconnected to the grid after the grid returns to normal. If the fault occurs repeatedly:</p> <ol style="list-style-type: none"> 1. Measure the actual grid, and contact the local electric power company for solutions if the grid parameter exceeds the set range. 2. If the fault still exists, contact SUNGROW.
17	Grid Voltage Imbalance	<p>Generally, the inverter will be reconnected to the grid after the grid returns to normal. If the fault occurs repeatedly:</p> <ol style="list-style-type: none"> 1. Measure the actual grid voltage. If grid phase voltages differ greatly, contact the electric power company for solutions. 2. If the voltage difference between phases is within the permissible range of the local power company, modify the grid voltage imbalance parameter through the App or the LCD. 3. If the fault still exists, contact SUNGROW.

Alarm ID	Alarm Name	Corrective Measures
28, 29, 208, 212, 448-479	PV Reverse Connection Fault	<p>1. Check whether the corresponding string is of reverse polarity. If so, disconnect the DC switch and adjust the polarity when the string current drops below 0.5 A.</p> <p>2. If the fault still exists, contact SUNGROW.</p> <p>*The code 28 to code 29 are corresponding to PV1 to PV2 respectively.</p> <p>*The code 448 to code 479 are corresponding to string 1 to string 32 respectively.</p>
532-547, 564-579	PV Reverse Connection Alarm	<p>1. Check whether the corresponding string is of reverse polarity. If so, disconnect the DC switch and adjust the polarity when the string current drops below 0.5 A.</p> <p>2. If the alarm still exists, contact SUNGROW.</p> <p>*The code 532 to code 547 are corresponding to string 1 to string 16 respectively.</p> <p>*The code 564 to code 579 are corresponding to string 17 to string 32 respectively.</p>
548-563, 580-595	PV Abnormal Alarm	<p>Check whether the voltage and current of the inverter is abnormal to determine the cause of the alarm.</p> <p>1. Check whether the corresponding module is sheltered. If so, remove the shelter and ensure module cleanness.</p> <p>2. Check whether the battery board wiring is loose, if so, make it reliably connected.</p> <p>3. Check if the DC fuse is damaged. If so, replace the fuse.</p> <p>4. If the alarm still exists, contact SUNGROW.</p> <p>*The code 548 to code 563 are corresponding to string 1 to string 16 respectively.</p> <p>*The code 580 to code 595 are corresponding to string 17 to string 32 respectively.</p>
37	Excessively High Ambient Temperature	<p>Generally, the inverter will resume operation when the internal or module temperature returns to normal. If the fault persists:</p> <p>1. Check whether the ambient temperature of the inverter is too high;</p> <p>2. Check whether the inverter is in a well-ventilated place;</p>

Alarm ID	Alarm Name	Corrective Measures
		<ol style="list-style-type: none"> 3. Check whether the inverter is exposed to direct sunlight. Shield it if so; 4. Check whether the fan is running properly. Replace the fan if not; 5. If the fault still exists, contact SUNGROW.
43	Excessively Low Ambient Temperature	<p>Stop and disconnect the inverter. Restart the inverter when the ambient temperature rises within the operation temperature range.</p>
39	Low System Insulation Resistance	<p>Wait for the inverter to return to normal. If the fault occurs repeatedly:</p> <ol style="list-style-type: none"> 1. Check whether the ISO resistance protection value is excessively high via the app or the LCD, and ensure that it complies with the local regulations. 2. Check the resistance to ground of the string and DC cable. Take corrective measures in case of short circuit or damaged insulation layer. 3. If the cable is normal and the fault occurs on rainy days, check it again when the weather turns fine. 4. If there are batteries, check whether battery cables are damaged and whether terminals are loose or in poor contact. If so, replace the damaged cable and secure terminals to ensure a reliable connection. 5. If the fault still exists, contact SUNGROW.
106	Grounding Cable Fault	<ol style="list-style-type: none"> 1. Check whether the AC cable is correctly connected. 2. Check whether the insulation between the ground cable and the live wire is normal. 3. If the fault still exists, contact SUNGROW.
88	Electric Arc Fault	<ol style="list-style-type: none"> 1. Disconnect the DC power supply, and check whether any DC cable is damaged, the connection terminal or fuse is loose or there is a weak contact. If so, replace the damaged cable, fasten the terminal or fuse, and replace the burnt component. 2. After performing step 1, reconnect the DC power supply, and clear the electric arc fault via the App or the LCD, after that the inverter will return to normal.

Alarm ID	Alarm Name	Corrective Measures
		3. If the fault still exists, contact SUNGROW.
51	Off-Grid Load OverPower Fault	1. Reduce the load power at the off-grid port or cut off some loads. 2. If the fault still exists, contact SUNGROW.
84	Reverse Connection Alarm of the Meter/CT	1. Check if the meter is wrongly connected. 2. Check if the input and output wiring of the meter is reversed. 3. If the existing system is enabled, please check if the rated power setting of the existing inverter is correct.
514	Meter Communication Abnormal Alarm	1. Check whether the communication cable and the terminals are abnormal. If so, correct them to ensure reliable connection. 2. Reconnect the communication cable of the meter. 3. If the alarm still exists, contact SUNGROW.
323	Grid Confrontation	1. Check whether the output port is connected to actual grid. Disconnect it from the grid if so. 2. If the fault still exists, contact SUNGROW.
75	Inverter Parallel Communication Alarm	1. Check whether the communication cable and the terminals are abnormal. If so, correct them to ensure reliable connection. 2. Reconnect the communication cable of the meter. 3. If the alarm still exists, contact SUNGROW.
714	BMS Communication Fault	1. Check whether the communication cable and the terminals are abnormal. If so, correct them to ensure reliable connection. 2. Reconnect the communication cable of the meter. 3. If the fault still exists, contact SUNGROW.
716	Abnormal Battery Connection	1. Check whether the battery is reversely connected or not connected. If so, correct the battery power cable connection. 2. If the fault still exists, contact SUNGROW.
932–935, 937, 939–	Battery Alarm	Generally, the battery can automatically recover. In case the alarm persist for a long time:

Alarm ID	Alarm Name	Corrective Measures
943, 964, 840		<ol style="list-style-type: none"> 1. If the alarm is caused by ambient temperature, such as over temperature alarm or low temperature alarm, take measures to change the ambient temperature, such as improving heat dissipation conditions. 2. If the fault persists, contact battery manufacturer.
703, 707, 708, 711, 712, 715, 717, 732– 737, 739– 747, 832– 837, 839, 841, 844, 864, 866– 868, 870, 1000, 1001	Battery Fault	<ol style="list-style-type: none"> 1. In case of abnormal battery voltage, check whether the battery power cable connection is abnormal (reverse connection, loose, etc.). If so, correct it to ensure reliable connection. 2. Check whether the battery real-time voltage is abnormal if the battery power cable is correctly connected. If so, contact the battery manufacturer. If not, contact SUNGROW. 3. In case of abnormal battery temperature, take measures to change the ambient temperature, such as improving heat dissipation conditions. 4. If the fault persists, contact battery manufacturer.
7, 11, 16, 19–25, 30–34, 36, 38, 40–42, 44–50, 52–58, 60–69, 85, 87, 92, 93, 100–105, 107–114, 116–124, 200–211, 248–255, 300–322, 324–328, 401–412, 600–603, 605, 608, 612, 616, 620, 622– 624, 800, 802, 804, 807,	System Fault	<ol style="list-style-type: none"> 1. Wait for the inverter to return to normal. 2. Disconnect the AC and DC switches, and disconnect the battery side switches if there are batteries. Close the AC and DC switches in turn 15 minutes later and restart the system. 3. If the fault still exists, contact SUNGROW.

Alarm ID	Alarm Name	Corrective Measures
1096– 1122		
59, 70–74, 76–83, 89, 216–218, 220–233, 432–434, 500–513, 515–518, 635–638, 900, 901, 910, 911, 996	System Alarm	<ol style="list-style-type: none"> 1. The inverter can continue running. 2. Check whether the related wiring and terminal are abnormal, check whether there are any foreign materials or other environmental abnormalities, and take corresponding corrective measures when necessary. 3. If the alarm persists, please contact SUNGROW.
264-283	MPPT Reverse Connection	<ol style="list-style-type: none"> 1. Check whether the corresponding string is of reverse polarity. If so, disconnect the DC switch and adjust the polarity when the string current drops below 0.5 A. 2. If the fault still exists, contact SUNGROW. <p>*The code 264 to code 279 are corresponding to string 1 to string 20 respectively.</p>
332-363	Boost Capacitor Overvoltage Alarm	<ol style="list-style-type: none"> 1. The inverter can continue running. 2. Check whether the related wiring and terminals are abnormal, check whether there are any foreign materials or other environmental abnormalities, and take corresponding corrective measures when necessary. 3. If the alarm persists, please contact SUNGROW.
364-395	Boost Capacitor Overvoltage Fault	<ol style="list-style-type: none"> 1. Disconnect the AC and DC switches, and disconnect the battery side switches if there are batteries. Close the AC and DC switches in turn 15 minutes later and restart the system. 2. If the fault still exists, contact SUNGROW.
1548-1579	String Current Reflux	<ol style="list-style-type: none"> 1. Check whether the number of PV modules of the corresponding string is less than other strings. If so, disconnect the DC switch and adjust the PV module configuration when the string current drops below 0.5 A. 2. Check whether the PV module is shaded.

Alarm ID	Alarm Name	Corrective Measures
		<p>3. Disconnect the DC switch to check whether the open circuit voltage is normal when the string current drops below 0.5 A. If so, check the wiring and configuration of the PV module.</p> <p>4. Check whether the orientation of the PV module is abnormal.</p>
1600 - 1615, 1632 - 1655	PV Grounding Fault	<p>1. When the fault occurs, it is forbidden to directly disconnect the DC switch and unplug PV terminals when the direct current is greater than 0.5 A;</p> <p>2. Wait until the direct current of the inverter falls below 0.5 A, then disconnect the DC switch and unplug the faulty strings;</p> <p>3. Do not reinsert the faulty strings before the grounding fault is cleared;</p> <p>4. If the fault is not caused by the foregoing reasons and still exists, contact Sungrow Customer Service.</p>
1616	System Hardware Fault	<p>1. It is prohibited to disconnect the DC switch when the DC current is greater than 0.5 A when the fault occurs.</p> <p>2. Disconnect the DC switch only when the inverter DC side current drops below 0.5 A.</p> <p>3. It is prohibited to power up the inverter again. Please contact Sungrow Customer Service.</p>

If the communication cable between the hybrid inverter and the battery is not connected correctly during the first installation, the battery may not work properly or the parameter information of the battery may not be displayed on the inverter. Please check the communication cable to ensure a correct connection.

10.2 Maintenance

10.2.1 Maintenance Notices

The DC switch can be secured with a lock in the OFF position or a certain angle beyond the OFF position.(For countries "AU" and "NZ")

⚠ DANGER

Risk of inverter damage or personal injury due to incorrect service!

- Be sure to use special insulation tools when perform high-voltage operations.
- Before any service work, first disconnect the grid-side AC circuit breaker and check the inverter status. If the inverter indicator is off, please wait until night to disconnect the DC switch. If the inverter indicator is on, directly disconnect the DC switch.
- After the inverter is powered off for 10 minutes, measure the voltage and current with professional instrument. Only when there is no voltage nor current can operators who wear protective equipment operate and maintain the inverter
- Even if the inverter is shut down, it may still be hot and cause burns. Wear protective gloves before operating the inverter after it cools down.
- When maintaining the product, it is strictly prohibited to open the product if there is an odor or smoke or if the product appearance is abnormal. If there is no odor, smoke, or obvious abnormal appearance, repair or restart the inverter according to the alarm corrective measures. Avoid standing directly in front of the inverter during maintenance.

⚠ CAUTION

To prevent misuse or accidents caused by unrelated personnel: Post prominent warning signs or demarcate safety warning areas around the inverter to prevent accidents caused by misuse.

NOTICE

Restart the inverter only after removing the fault that impairs safety performance. As the inverter contains no component parts that can be maintained, never open the enclosure, or replace any internal components.

To avoid the risk of electric shock, do not perform any other maintenance operations beyond those described in this manual. If necessary, contact your distributor first. If the problem persists, contact SUNGROW. Otherwise, the losses caused is not covered by the warranty.

NOTICE

Touching the PCB or other static sensitive components may cause damage to the device.

- Do not touch the circuit board unnecessarily.
- Observe the regulations to protect against electrostatic and wear an anti-static wrist strap.

10.2.2 Routine Maintenance

Item	Method	Period
Device clean	Check the temperature and dust of the device. Clean the device enclosure if necessary.	Six months to a year (depending on the dust contents in air)
Electrical connection	Check whether all cable are firmly connected in place. Check whether there is damage to the cables, especially the surface in contact with metal.	6 months after commissioning and then once or twice a year
General status of the system	<ul style="list-style-type: none"> • Visual check for any damage or deformation of the microinverter. • Check any abnormal noise during the operation. • Check each operation parameter. • Be sure that nothing covers the heat sink of the device. 	Every 6 months

11 Appendix

11.1 Technical Data

Parameter	SH8.0RS	SH10RS
Input (DC)		
Recommended max. PV input power	16000 Wp	20000 Wp
Max. PV input voltage *	600 V	
Min. operating PV voltage / Start-up input voltage	40 V / 50 V	
Rated PV input voltage	360 V	
MPPT operating voltage range	40 V - 560 V	
MPP voltage range for rated power	190 V - 480 V	235 V - 480 V
No. of independent MPP inputs	4	
No. of PV strings per MPPT	1 / 1 / 1 / 1	
Max. PV input current	64 A (16 A / 16 A / 16 A / 16 A)	
Max. DC short-circuit current	100 A (25 A / 25 A / 25 A / 25 A)	
Max. current for input connector	20 A	
Input / Output (AC)		
Max. AC input power from grid	14500 VA	
Rated AC output power	8000 W	10000 W 9999 W for Australia
Max. AC output apparent power	8000 VA	10000 VA 9999VA for Australia

Parameter	SH8.0RS	SH10RS
Rated AC output apparent power	8000 VA	10000 VA 9999VA for Australia
Max. AC output current	36.4 A	45.5 A
Rated. AC output current	34.78 A	43.48 A
Rated AC voltage	230 V	
AC voltage range	154 V - 276 V	
Rated grid frequency	50 Hz / 60Hz	
Grid frequency range	45 Hz – 55 Hz / 55 Hz – 65 Hz	
Harmonic (THD)	< 3 % (of rated power)	
Power factor at rated power / Adjustable power factor	> 0.99 / 0.8 leading – 0.8 lagging	
Feed-in phases / connection phases	1 / 1	
Efficiency		
Max. efficiency / European efficiency	97.4% / 96.8%	97.5% / 97.1%
Protection		
Grid monitoring	Yes	
DC reverse polarity protection	Yes	
AC short circuit protection	Yes	
Leakage current protection	Yes	
Surge Protection	DC Type II / AC Type II **	
DC switch (solar)	Yes	
PID Zero	Yes	
Battery input reverse polarity protection	Yes	
Protective Class	I	

Parameter	SH8.0RS	SH10RS
Overvoltage Category	III for AC, II for PV & BAT	
Active Anti-Islanding Method	Frequency Shift	
Battery Data		
Battery type	Li-ion battery	
Battery voltage	80 V - 460 V	
Max. charge / discharge current	50 A*** / 50 A***	
Max. charge / discharge power	10000 W / 10000 W	
General Data		
Dimensions (W x H x D)	605 mm x 435 mm x 181 mm	
Weight	29 kg	
Mounting method	Wall-mounting bracket	
Topology (Solar / Battery)	Transformerless / Transformerless	
Degree of protection	IP65	
Operating ambient temperature range	-25°C to 60°C	
Allowable relative humidity range	0 - 100 %	
Cooling method	Natural convection	
Max. operating altitude	4000 m	
Noise (typical)	35 dB (A) 45 dB (A) for Australia	
Display	LED digital display and LED indicator	
Communication	RS485, WLAN, Ethernet, CAN	
DI / DO	DI*1 / DO*2 / DRM0	
DC connection type	MC4 (PV, Max.6mm ²) / Plug and play connector (battery, Max.10mm ²)	
AC connection type	Plug and play connector (Max.16mm ²)	

Parameter	SH8.0RS	SH10RS
Country of manufacture		China
Pollution degree		3
Backup Data (on grid mode)		
Rated output power for backup load		14500 W
Rated output current for backup load		63 A
Backup Data (off-grid mode)		
Rated voltage		230 V
Frequency range		50 Hz / 60 Hz ($\pm 0.2\%$)
Total output THDv for linear load		< 2 %
Switch time to emergency mode		< 10 ms
Rated output power	8000 W / 8000 VA	10000 W / 10000 VA 9999 W / 9999 VA for Australia
Peak output power		13680 VA, 10s

* Input voltage exceeding the MPPT operating voltage range triggers inverter protection.

** Only when the DC switch is set to "ON", the DC Type II is able to provide effective protection against electrical surges.

*** Depending on the connected battery.

11.2 Quality Assurance

When product faults occur during the warranty period, SUNGROW will provide free service or replace the product with a new one.

The software security update period for this product aligns with the warranty period. During the warranty, security patches or updates will be provided if any vulnerabilities or compatibility issues are identified.

Evidence

During the warranty period, the customer shall provide the product purchase invoice and date. In addition, the trademark on the product shall be undamaged and legible. Otherwise, SUNGROW has the right to refuse to honor the quality guarantee.

Conditions

- After replacement, unqualified products shall be processed by SUNGROW.
- The customer shall give SUNGROW a reasonable period to repair the faulty device.

Exclusion of Liability

In the following circumstances, SUNGROW has the right to refuse to honor the quality guarantee:

- The free warranty period for the whole machine/components has expired.
- The device is damaged during transport.
- The device is incorrectly installed, refitted, or used.
- The device operates in harsh conditions beyond those described in this manual.
- The fault or damage is caused by installation, repairs, modification, or disassembly performed by a service provider or personnel not from SUNGROW.
- The fault or damage is caused by the use of non-standard or non-SUNGROW components or software.
- The installation and use range are beyond stipulations of relevant international standards.
- The damage is caused by unexpected natural factors.

For faulty products in any of above cases, if the customer requests maintenance, paid maintenance service may be provided based on the judgment of SUNGROW.

Product data such as product dimensions are subject to change without prior notice. The latest documentation from SUNGROW should take precedence in case of any deviation.

11.3 Contact Information

In case of questions about this product, please contact us. We need the following information to provide you the best assistance:

- Model of the device
- Serial number of the device
- Fault code/name
- Brief description of the problem

For detailed contact information, please visit: <https://en.SUNGROWpower.com/contactUS>

Sungrow Power Supply Co., Ltd.

www.sungrowpower.com